

## CASES 995-S-20 & 996-V-20 - REVISED

SUPPLEMENTAL MEMORANDUM #2

May 18, 2021

**Petitioners:** Adam & Jodi Kimball

**Request:** Case 995-S-20

Authorize multiple principal structures on the same lot consisting of self-storage warehouses previously authorized in Cases 977-S-20 and 979-V-20 and a sign structure with four off-premises freestanding advertising signs as a Special Use in the B-3 Highway Business Zoning District, subject to approval of the variances requested in related Case 996-V-20.

Case 996-V-20

Authorize the following variances for the Special Use Permit requested in related Zoning Case 995-S-20 for proposed off-premises signs in the B-3 Highway Business Zoning District, per Section 7.3.5 of the Zoning Ordinance:

Part A: A variance for four off-premises freestanding advertising signs on one sign structure on one frontage that total ~~1,152~~ 589 square feet in sign face area in lieu of the maximum allowed one off-premises sign per frontage that totals 300 square feet in sign face area.

Part B: A variance for four off-premises freestanding advertising signs on one sign structure with a maximum height of ~~37~~ 35.5 feet in lieu of the maximum allowed 30 feet.

~~Part C: A variance for four off-premises freestanding advertising signs on one sign structure in addition to an on-premises sign along the same IL Route 47 frontage, in lieu of the maximum allowed one sign per frontage.~~  
WITHDRAWN BY PETITIONER

Part C: A variance for four off-premises freestanding advertising signs on one sign structure with a setback of ~~64~~ 72.5 feet from the street centerline of IL Route 47 and a front yard of ~~23~~ 31.5 feet, in lieu of the minimum required setback of 85 feet and front yard of 35 feet along a State highway.

**Location:** A 3.36-acre tract in the South Half of the Northeast Quarter of Section 9, Township 19 North, Range 7 East of the Third Principal Meridian in Scott Township, and commonly known as the tract just east of the residence with an address of 285 CR 1675N, Seymour.

**Site Area:** 3.36 acres

**Time Schedule for Development:** As soon as possible

**Prepared by:** Susan Burgstrom, Senior Planner  
John Hall, Zoning Administrator

## STATUS

At the March 27, 2021 ZBA meeting, the Board told Mr. Kimball that they would like to see a revised application for the billboard structure proposing a specific and reduced size rather than a range of sizes to consider. On April 14, 2021, P&Z Staff received a revised Plan and Elevation View of a smaller structure with smaller sign faces. The petitioner also indicated that variance part C for number of signs on one frontage is no longer necessary, because he will put the on-premises advertising sign along CR 1675 N instead of along the IL-47 frontage. Variance Part D will be renamed Part C.

The revised plan view reduces the requested variances in Case 996-V-20 in the following manner:

Variance Part	Original Request	Revised Request	Maximum allowed
A total sign face area	1,152 sf	589 sf	300 sf
B height	37'	35.5'	30'
C setback and front yard on IL-47	64' setback 23' front yard	72.5' setback 31.5' front yard	85' setback 35' front yard

John Hall, Zoning Administrator, suggested that Mr. Kimball check with Ameren to see if there are any concerns with the adjacent utility lines. In the April 14, 2021 email, Mr. Kimball stated, "Ameren is good with this. The sign is 37' from the power lines and is ~16 feet wide, so any point of the sign is at least 20' from the power lines." He said that he spoke by phone with Ameren representative Elmer Crawford.

## PROPOSED SPECIAL CONDITIONS

- A. **The Zoning Administrator shall not authorize a Zoning Use Permit or a Zoning Compliance Certificate until the petitioner has demonstrated that any new or proposed exterior lighting on the subject property will comply with the lighting requirements of Section 6.1.2.**

The special condition stated above is required to ensure the following:

**That the proposed uses are in compliance with the Zoning Ordinance.**

- B. **Regarding the existing on-premises advertising sign, within 30 days of approval of Zoning Cases 995-S-20 and 996-V-20, the petitioner must either:**
- (1) **Provide written verification to the P&Z Department that the sign is temporary and will be removed with 14 days of completing construction of the first self-storage building, or**
  - (2) **Apply for a Zoning Use Permit for the permanent sign, pay the corresponding fee, and receive permit approval, or remove the sign.**

The special condition stated above is required to ensure the following:

**That all structures on the property comply with the Zoning Ordinance.**

- C. **Any future sale of the subject property may be subject to the Illinois Plat Act (765 ILCS 205/0.01 et seq.) or the Champaign County Subdivision Regulations; or the subdivision**

**regulations of a municipality that has jurisdiction within one and one-half miles of the corporate limits.**

The special condition stated above is required to ensure the following:

**That the subject property complies with the Zoning Ordinance.**

#### **ATTACHMENTS**

- A Email string between Mr. Kimball and John Hall dated April 14, 2021, with attachment:
  - Revised Plan and Elevation View of the billboard
  
- B Cases 995-S-20 and 996-V-20 Revised Summary of Evidence, Draft Summary Finding of Fact, and Final Determination dated May 27, 2021

## Susan Burgstrom

---

**From:** John Hall  
**Sent:** Monday, April 26, 2021 8:51 AM  
**To:** Susan Burgstrom  
**Subject:** FW: Kimball Sign Resubmittal

**Follow Up Flag:** Follow up  
**Flag Status:** Flagged

---

**From:** Adam Kimball <[adamkimball14@gmail.com](mailto:adamkimball14@gmail.com)>  
**Sent:** Wednesday, April 14, 2021 12:38 PM  
**To:** John Hall <[jhall@co.champaign.il.us](mailto:jhall@co.champaign.il.us)>  
**Subject:** Re: Kimball Sign Resubmittal

phone - Elmer Crawford Ameren

RECEIVED

APR 14 2021

CHAMPAIGN CO. P & Z DEPARTMENT

On Wed, Apr 14, 2021 at 11:34 AM John Hall <[jhall@co.champaign.il.us](mailto:jhall@co.champaign.il.us)> wrote:

Great!

Is there an email or was this a phone conversation? Who did you talk to so we can at least report the name of that person?

---

**From:** Adam Kimball <[adamkimball14@gmail.com](mailto:adamkimball14@gmail.com)>  
**Sent:** Wednesday, April 14, 2021 11:21 AM  
**To:** John Hall <[jhall@co.champaign.il.us](mailto:jhall@co.champaign.il.us)>  
**Subject:** Re: Kimball Sign Resubmittal

Ameren is good with this. the sign is 37' from the power lines and is ~16 feet wide so any point of the sign is at least 20' from the power lines.

On Wed, Mar 31, 2021 at 7:25 PM Adam Kimball <[adamkimball14@gmail.com](mailto:adamkimball14@gmail.com)> wrote:

Yes, good idea. I will reach out to them now.

On Wed, Mar 31, 2021 at 11:49 AM John Hall <[jhall@co.champaign.il.us](mailto:jhall@co.champaign.il.us)> wrote:

Were you planning to contact Ameren to see if they have any concerns? I think it would help if you can provide some kind of affirmation from Ameren that they have no concerns.

It would be good to have that info before the meeting and I still have to let you know when that meeting will be.

Sincerely,

**John Hall**

---

**From:** Adam Kimball <[adamkimball14@gmail.com](mailto:adamkimball14@gmail.com)>  
**Sent:** Wednesday, March 31, 2021 11:34 AM  
**To:** John Hall <[jhall@co.champaign.il.us](mailto:jhall@co.champaign.il.us)>  
**Subject:** Re: Kimball Sign Resubmittal

Here you go.

On Wed, Mar 31, 2021 at 11:31 AM John Hall <[jhall@co.champaign.il.us](mailto:jhall@co.champaign.il.us)> wrote:

I think that will help.

---

**From:** Adam Kimball <[adamkimball14@gmail.com](mailto:adamkimball14@gmail.com)>  
**Sent:** Wednesday, March 31, 2021 11:30 AM  
**To:** John Hall <[jhall@co.champaign.il.us](mailto:jhall@co.champaign.il.us)>  
**Subject:** Re: Kimball Sign Resubmittal

Yes, we can raise that to accommodate. It is detailed out at 10' 6" , but we can raise it. For some reason I thought it was 13' not 13' 6" but I think you are right. the total height at 13' was 35' but adding the 6" to it we would need to go 35' 6". But yes, that is fine. I will note up the dimension change from 10' 6" to 13' 6" and resubmit.

On Wed, Mar 31, 2021 at 7:59 AM John Hall <[jhall@co.champaign.il.us](mailto:jhall@co.champaign.il.us)> wrote:

Good morning.

The ground clearance may still be an issue. Did you consider revising this to provide the 13'-6" ground clearance that was mentioned in the public hearing?

Sincerely,

**John Hall**  
Director  
Zoning Administrator

***Champaign County Department of Planning and Zoning***

Brookens Administrative Center  
1776 East Washington Street  
Urbana IL 61802  
Tel (217) 384-3708  
Fax (217) (819-4021)

---

**From:** Adam Kimball <[adamkimball14@gmail.com](mailto:adamkimball14@gmail.com)>  
**Sent:** Tuesday, March 30, 2021 6:39 PM  
**To:** John Hall <[jhall@co.champaign.il.us](mailto:jhall@co.champaign.il.us)>  
**Subject:** Re: Kimball Sign Resubmittal

thanks John.

Attached is a reduced version of the original submission. Faces reduced to 9.5'x15.5' or a total of 589 sqft versus the 1152 originally submitted. Part B reduced to 35'. Part C can be deleted. I will not have a freestanding sign for the storage on IL 47 that will be on CR1675. I might have a sign on the building that has the phone number on it but no freestanding sign along IL 47.

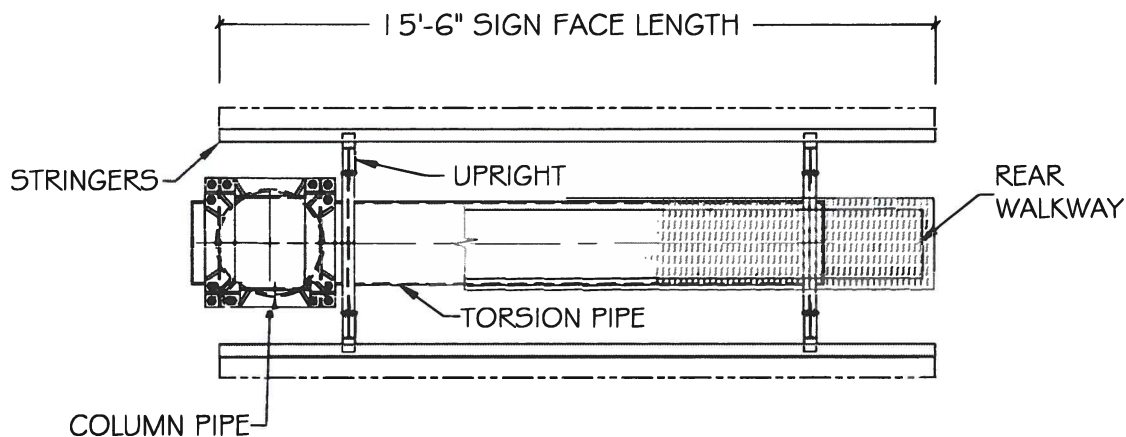

PLAN VIEW

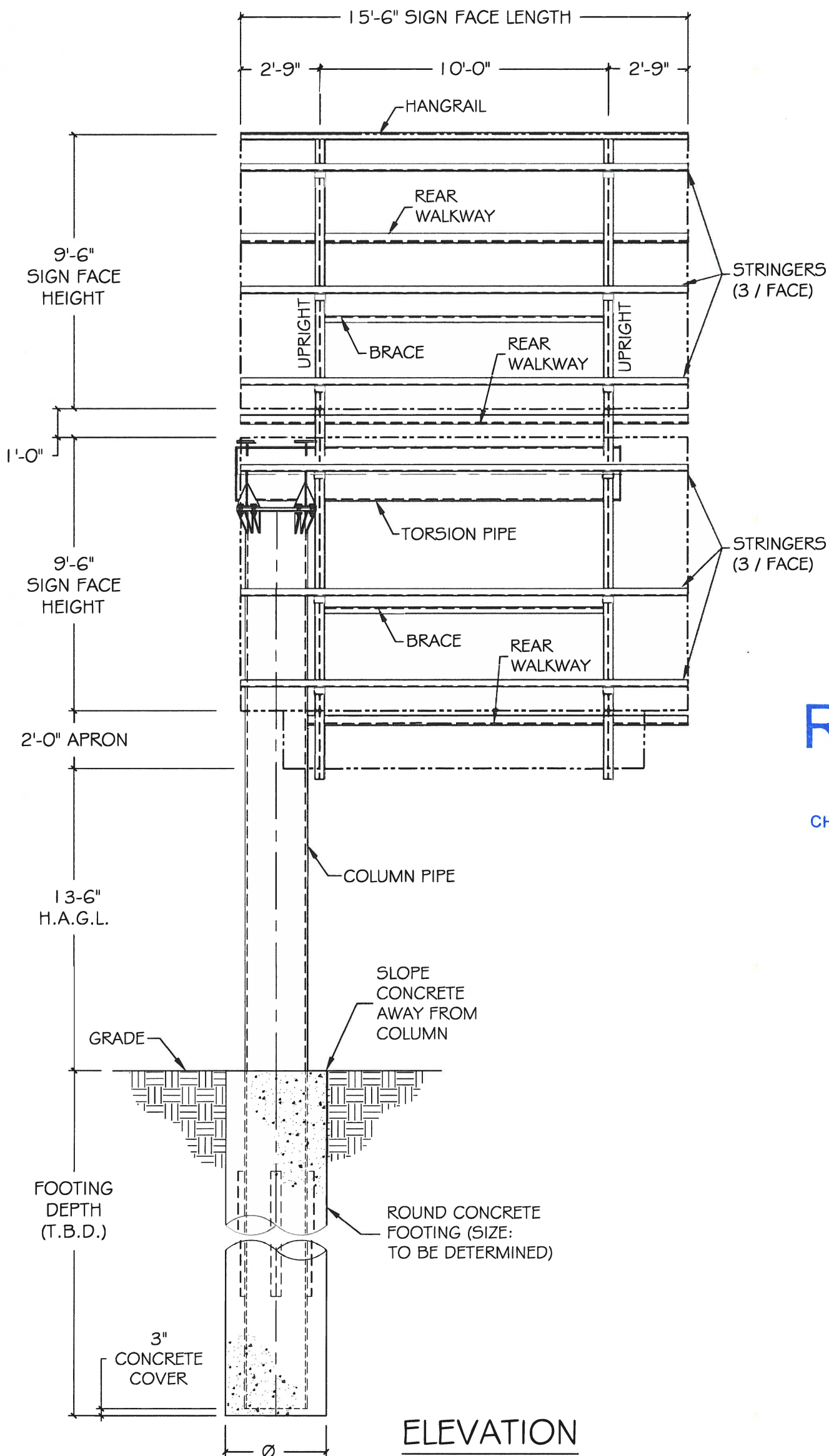

ELEVATION

RECEIVED

APR 14 2021

CHAMPAIGN CO. P & Z DEPARTMENT

CUSTOMER		
ADAM KIMBALL		
SIGN LOCATION		
SEYMOUR, IL		
 <small>4425 North 24th Street, Suite 200 Phoenix, Arizona 85016 (602) 230-8634 Fax: (602) 230-8071</small>		
9'-6" x 15'-6" FULL FLAG STACKED BACK TO BACK SIGN STRUCTURE		
DRAWING NO.	DR.	CH.
PLAN VIEW #	DBM	JS
ELEVATION	DATE	
	03/29/2021	
JOB NO.	SHEET NO.	
	1 of 1	

**REVISED DRAFT 05/27/21**

**995-S-20 & 996-V-20 - REVISED**

**SUMMARY OF EVIDENCE, FINDING OF FACT  
AND FINAL DETERMINATION  
of  
Champaign County Zoning Board of Appeals**

---

Final Determination: ***{GRANTED/ GRANTED WITH SPECIAL CONDITIONS/ DENIED}***

Date: ***{May 27, 2021}***

Petitioners: **Adam & Jodi Kimball**

Request: **CASE 995-S-20**

**Authorize multiple principal structures on the same lot consisting of self-storage warehouses previously authorized in Cases 977-S-20 and 979-V-20 and a sign structure with four off-premises freestanding advertising signs as a Special Use in the B-3 Highway Business Zoning District, subject to approval of the variances requested in related Case 996-V-20.**

**CASE 996-V-20**

**Authorize the following variances for the Special Use Permit requested in related Zoning Case 995-S-20 for proposed off-premises signs in the B-3 Highway Business Zoning District, per Section 7.3.5 of the Zoning Ordinance:**

**Part A:** A variance for four off-premises freestanding advertising signs on one sign structure on one frontage that total ~~1,152~~ 589 square feet in sign face area in lieu of the maximum allowed one off-premises sign per frontage that totals 300 square feet in sign face area.

**Part B:** A variance for four off-premises freestanding advertising signs on one sign structure with a maximum height of ~~37~~ 35.5 feet in lieu of the maximum allowed 30 feet.

~~**Part C:** A variance for four off-premises freestanding advertising signs on one sign structure in addition to an on-premises sign along the same IL Route 47 frontage, in lieu of the maximum allowed one sign per frontage.~~

**Part C:** A variance for four off-premises freestanding advertising signs on one sign structure with a setback of ~~64~~ 72.5 feet from the street centerline of IL Route 47 and a front yard of ~~23~~ 31.5 feet, in lieu of the minimum required setback of 85 feet and front yard of 35 feet along a State highway.

---

**Cases 995-S-20 & 996-V-20 - REVISED *REVISED DRAFT 05/27/21***

Page 2 of 29

**Table of Contents**

**General Application Information.....2 - 5**

**Specific Ordinance Requirements.....5 - 10**

**Special Use and Variance Evidence .....10 - 21**

**Documents of Record..... 22**

**Case 995-S-20 Summary Draft Finding of Fact.....23 - 25**

**Case 996-V-20 Summary Draft Finding of Fact .....26 - 27**

**Case 995-S-20 Final Determination..... 28**

**Case 996-V-20 Final Determination ..... 29**



**REVISED DRAFT 05/27/21 Cases 995-S-20 & 996-V-20 - REVISED**  
Page 3 of 29

**SUMMARY OF EVIDENCE**

From the documents of record and the testimony and exhibits received at the public hearing conducted on **January 28, 2021, March 25, 2021, and May 27, 2021**, the Zoning Board of Appeals of Champaign County finds that:

1. Petitioners Adam & Jodi Kimball own the subject property.
2. The subject property is a 3.36-acre tract in the South Half of the Northeast Quarter of Section 9, Township 19 North, Range 7 East of the Third Principal Meridian in Scott Township, and commonly known as the tract just east of the residence with an address of 285 CR 1675N, Seymour.
3. Regarding municipal extraterritorial jurisdiction and township planning jurisdiction:
  - A. The subject property is not located within the one and one-half mile extraterritorial of a municipality with zoning.
  - B. The subject property is located in Scott Township, which does not have a Plan Commission.

**GENERALLY REGARDING LAND USE AND ZONING IN THE IMMEDIATE VICINITY**

4. Land use and zoning on the subject property and in the vicinity adjacent to the subject property are as follows:
  - A. The 3.36-acre subject property is zoned B-3 Highway Business and is in agricultural production. The property is about 300 feet north of the I-72 interchange on the west side of IL Route 47.
    - (1) The petitioners received approval to construct up to 290 self-storage warehouse units on the subject property in Cases 977-S-20 and 979-V-20; construction has not started.
  - B. Land to the north is zoned AG-1 Agriculture and is in agricultural production.
  - C. Land to the east is zoned B-3 Highway Business and is in agricultural production.
  - D. Land to the west is split-zoned AG-1 Agriculture and B-3 Highway Business, and is residential and agricultural in use.
  - E. Land to the south is split-zoned AG-1 Agriculture and B-3 Highway Business, and is in agricultural production.

**GENERALLY REGARDING THE PROPOSED SPECIAL USE**

5. Regarding the site plan and operations of the proposed Special Use:
  - A. The Site Plan received December 23, 2020 consists of a Site Plan sheet prepared by Hartke Engineering & Surveying and a Plan View Sheet prepared by RMG Outdoor Inc, which include the following features:
    - (1) Existing features include:
      - a. One 28 feet by 40 feet crib built prior to approval of the Zoning Ordinance on October 10, 1973. This crib would be demolished with construction of the self-storage units.

**Cases 995-S-20 & 996-V-20 - REVISED *REVISED DRAFT 05/27/21***

Page 4 of 29

- b. One on-premises advertising sign, measurements unknown, but approximately 12 feet high and 8 feet wide, installed without a permit sometime after approval of zoning cases 977-S-20 and 979-V-20 were approved on August 15, 2020.
- (2) Proposed features include:
  - a. Up to six buildings with up to 290 self-storage warehouses, as approved in Cases 977-S-20 and 979-V-20.
  - b. One sign structure to be installed at the northeast corner of the easternmost proposed building, which will have four 24 feet by 12 feet billboards, two facing in each direction (north and south).
    - (a) A Plan View of the billboard structure received on December 23, 2020 indicates that the bottom of the lower billboard will be about 13 feet off the ground, and the full height would be 37 feet.
  - c. The petitioner has mentioned having an on-premises advertising sign and wall signs on the self-storage warehouses, but no details have been provided. It is unknown if the existing on-premises advertising sign is temporary or would need a permit to remain onsite.
    - (a) Section 7.3.3 J. of the Zoning Ordinance allows temporary, on-premises Individual PROPERTY Sale or Rental SIGNS without a permit, subject to the standards provided in Section 7.3.7.
- B. A revised Plan and Elevation View of the billboard received April 14, 2021 includes the following dimensions:
  - (1) Reduced sign faces of 15.5 feet by 9.5 feet (147.25 square feet each), for a reduced total sign face area of 589 square feet;
  - (2) Reduced height of 35.5 feet;
  - (3) Increased setback on IL-47 of 72.5 feet; and
  - (4) Increased front yard on IL-47 of 31.5 feet.
- C. There are no previous Zoning Use Permits for the subject property.
- D. There are two previous zoning cases for the subject property:
  - (1) Case 977-S-20 was approved on August 15, 2020 for Adam & Jodi Kimball to construct up to 290 self-storage warehouses.
  - (2) Case 979-V-20 was approved on August 15, 2020 to allow the Kimballs not to construct loading berths for the self-storage units and for a front yard of 29 feet along IL Route 47.
- E. The proposed variances are for the following:
  - (1) Part A is to allow ~~1,152~~ 589 square feet of billboard face in lieu of the maximum allowed 300 square feet.

**REVISED DRAFT 05/27/21 Cases 995-S-20 & 996-V-20 - REVISED**

- (2) Part B is to allow a billboard structure that is ~~37~~ 35.5 feet high in lieu of the maximum allowed 30 feet in height.
- (3) Part C is to allow an off-premises freestanding sign in addition to an on-premises sign along the same IL Route 47 frontage, in lieu of the maximum allowed one sign per frontage.
- (4) Part D is to allow a setback of ~~64~~ 72.5 feet and a front yard of ~~23~~ 31.5 feet from the billboard structure on the east side, in lieu of a minimum setback of 85 feet and a minimum front yard of 35 feet along a State highway.

**GENERALLY REGARDING SPECIFIC ORDINANCE REQUIREMENTS**

6. Regarding authorization for self-storage warehouses providing heat and utilities to individual units in the B-3 Highway Business Zoning DISTRICT in the *Zoning Ordinance*:

A. The following definitions from the *Zoning Ordinance* are especially relevant to the requested Special Use Permit (capitalized words are defined in the Ordinance):

- (1) “BEST PRIME FARMLAND” is Prime Farmland Soils identified in the Champaign County Land Evaluation and Site Assessment (LESA) System that under optimum management have 91% to 100% of the highest soil productivities in Champaign County, on average, as reported in the Bulletin 811 Optimum Crop Productivity Ratings for Illinois Soils. Best Prime Farmland consists of the following:
  - a. Soils identified as Agriculture Value Groups 1, 2, 3 and/or 4 in the Champaign County LESA system;
  - b. Soils that, in combination on a subject site, have an average LE of 91 or higher, as determined by the Champaign County LESA system;
  - c. Any development site that includes a significant amount (10% or more of the area proposed to be developed) of Agriculture Value Groups 1, 2, 3 and/or 4 soils as determined by the Champaign County LESA system.
- (2) “FRONTAGE” is that portion of a LOT abutting a STREET or ALLEY.
- (3) “HEIGHT” as applied to a story is the vertical measurement between the surface of any floor and the surface of the floor next above it, or if there is no floor above, then the vertical measurement between the surface of the floor and the ceiling next above it.

As applied to a BUILDING is the vertical measurement from GRADE to a point midway between the highest and lowest points of the roof.

As Applied to an Enclosed or Unenclosed STRUCTURE:

STRUCTURE, DETACHED: The vertical measurement from the average level of the surface of the ground immediately surrounding such STRUCTURE to the uppermost portion of such STRUCTURE.

STRUCTURE, ATTACHED: Where such STRUCTURE is attached to another STRUCTURE and is in direct contact with the surface of the ground, the vertical measurement from the average level of the surface of the ground

**Cases 995-S-20 & 996-V-20 - REVISED *REVISED DRAFT 05/27/21***

Page 6 of 29

immediately adjoining such STRUCTURE to the uppermost portion of such STRUCTURE shall be the HEIGHT. Where such STRUCTURE is attached to another STRUCTURE and is not in direct contact with the surface of the ground, the vertical measurement from the lowest portion of such STRUCTURE to the uppermost portion shall be the HEIGHT.

- (4) "LOT" is a designated parcel, tract or area of land established by PLAT, SUBDIVISION or as otherwise permitted by law, to be used, developed or built upon as a unit.
- (5) "LOT LINE, FRONT" is a line dividing a LOT from a STREET or easement of ACCESS. On a CORNER LOT or a LOT otherwise abutting more than one STREET or easement of ACCESS only one such LOT LINE shall be deemed the FRONT LOT LINE.
- (6) "RIGHT-OF-WAY" is the entire dedicated tract or strip of land that is to be used by the public for circulation and service.
- (7) "SIGN" is any name, identification, description, display, illustration or device which is affixed to or represented directly or indirectly upon a BUILDING, STRUCTURE or land which is placed out-of-doors and in view of the general public and which directs attention to a product, place, activity, person, institution, or business.
- (8) "SIGN, FREESTANDING" is a SIGN which is completely or principally self-supported by posts or other supports independent of any BUILDING or other STRUCTURE.
- (9) "SIGN, OFF-PREMISES" is a SIGN which directs attention to a USE, business, commodity, service or activity not conducted, sold, or offered upon the PREMISES where the SIGN is located. Such SIGNS shall be considered a principal USE of a PROPERTY.
- (10) "SIGN, ON-PREMISES" is a SIGN which relates solely to a USE, business or profession conducted upon, or to a principal commodity, service, or entertainment sold, provided, or offered upon the PREMISES where the sign is located or on a LOT adjacent to the PREMISES advertised. Such SIGNS shall be ACCESSORY USES of a PROPERTY.
- (11) "SPECIAL CONDITION" is a condition for the establishment of a SPECIAL USE.
- (12) "SPECIAL USE" is a USE which may be permitted in a DISTRICT pursuant to, and in compliance with, procedures specified herein.
- (13) "STREET" is a thoroughfare dedicated to the public within a RIGHT-OF-WAY which affords the principal means of ACCESS to abutting PROPERTY. A STREET may be designated as an avenue, a boulevard, a drive, a highway, a lane, a parkway, a place, a road, a thoroughfare, or by other appropriate names. STREETS

**REVISED DRAFT 05/27/21 Cases 995-S-20 & 996-V-20 - REVISED**

Page 7 of 29

are identified on the Official Zoning Map according to type of USE, and generally as follows:

- (a) MAJOR STREET: Federal or State highways.
  - (b) COLLECTOR STREET: COUNTY highways and urban arterial STREETS.
  - (c) MINOR STREET: Township roads and other local roads.
- (14) “STRUCTURE” is anything CONSTRUCTED or erected with a fixed location on the surface of the ground or affixed to something having a fixed location on the surface of the ground. Among other things, STRUCTURES include BUILDINGS, walls, fences, billboards, and SIGNS.
- (15) “STRUCTURE, MAIN or PRINCIPAL” is the STRUCTURE in or on which is conducted the main or principal USE of the LOT on which it is located.
- (16) “SUITED OVERALL” is a discretionary review performance standard to describe the site on which a development is proposed. A site may be found to be SUITED OVERALL if the site meets these criteria:
- a. The site features or site location will not detract from the proposed use;
  - b. The site will not create a risk to health, safety or property of the occupants, the neighbors or the general public;
  - c. The site is not clearly inadequate in one respect even if it is acceptable in other respects;
  - d. Necessary infrastructure is in place or provided by the proposed development; and
  - e. Available public services are adequate to support the proposed development effectively and safely.
- (17) “USE” is the specific purpose for which land, a STRUCTURE or PREMISES, is designed, arranged, intended, or for which it is or may be occupied or maintained. The term “permitted USE” or its equivalent shall not be deemed to include any NONCONFORMING USE.
- (18) “VARIANCE” is a deviation from the regulations or standards adopted by this ordinance which the Hearing Officer or the Zoning BOARD of Appeals are permitted to grant.
- (19) “WAREHOUSE, SELF-STORAGE” is a BUILDING or BUILDINGS containing multiple, independently accessible spaces where raw materials, goods or equipment, or personal goods including personal vehicles, are kept and wherein no other commercial or industrial activity occurs.
- B. Section 4.2.1 F.1. states, “It shall be unlawful to erect or establish more than one MAIN or PRINCIPAL STRUCTURE or BUILDING per LOT or increase or expand an existing STRUCTURE or BUILDING on a LOT having more than one existing PRINCIPAL STRUCTURE or BUILDING constructed prior to the adoption of this Ordinance in the following zoning DISTRICTS except as provided in Section 4.2.1 D. unless a SPECIAL USE Permit has been obtained from the BOARD: R-4 Multiple Family Residence, B-1 Rural Trade Center, B-2 Neighborhood Business, B-3 Highway Business, B-4 General Business, B-5 Central Business, I-1 Light Industry, I-2 Heavy Industry.”

**Cases 995-S-20 & 996-V-20 - REVISED *REVISED DRAFT 05/27/21***

Page 8 of 29

- C. Section 5.2: Table of Authorized Principal Uses states:
  - (1) “Self-storage Warehouses providing heat and utilities to individual units” can be established with a Special Use Permit in the B-3 Highway Business Zoning District.
  - (2) “Off-premises signs” are authorized by-right in the B-3 Highway Business Zoning District.
  
- D. Subsection 6.1 contains standard conditions that apply to all SPECIAL USES, standard conditions that may apply to all SPECIAL USES, and standard conditions for specific types of SPECIAL USES. Relevant requirements from Subsection 6.1 are as follows:
  - (1) Paragraph 6.1.2 A. indicates that all Special Use Permits with exterior lighting shall be required to minimize glare on adjacent properties and roadways by the following means:
    - a. All exterior light fixtures shall be full-cutoff type lighting fixtures and shall be located and installed so as to minimize glare and light trespass. Full cutoff means that the lighting fixture emits no light above the horizontal plane.
    - b. No lamp shall be greater than 250 watts and the Board may require smaller lamps when necessary.
    - c. Locations and numbers of fixtures shall be indicated on the site plan (including floor plans and building elevations) approved by the Board.
    - d. The Board may also require conditions regarding the hours of operation and other conditions for outdoor recreational uses and other large outdoor lighting installations.
    - e. The Zoning Administrator shall not approve a Zoning Use Permit without the manufacturer’s documentation of the full-cutoff feature for all exterior light fixtures.
  - (2) There are no Standard Conditions for Self-storage units or off-premises signs in Section 6.1.3 of the Zoning Ordinance.
  
- E. Paragraph 9.1.9 D. of the Zoning Ordinance requires the ZBA to make the following findings for a variance:
  - (1) That the requirements of Paragraph 9.1.9 C. have been met and justify granting the variance. Paragraph 9.1.9 C. of the Zoning Ordinance states that a variance from the terms of the Champaign County Zoning Ordinance shall not be granted by the Board or the hearing officer unless a written application for a variance is submitted demonstrating all of the following:
    - a. That special conditions and circumstances exist which are peculiar to the land or structure involved that are not applicable to other similarly situated land or structures elsewhere in the same district.
    - b. That practical difficulties or hardships created by carrying out the strict letter of the regulations sought to be varied prevent reasonable and otherwise permitted use of the land or structures or construction on the lot.

**REVISED DRAFT 05/27/21 Cases 995-S-20 & 996-V-20 - REVISED**

Page 9 of 29

- c. That the special conditions, circumstances, hardships, or practical difficulties do not result from actions of the Applicant.
  - d. That the granting of the variance is in harmony with the general purpose and intent of the Ordinance.
  - e. That the granting of the variance will not be injurious to the neighborhood, or otherwise detrimental to the public health, safety, or welfare.
- (2) That the variance is the minimum variation that will make possible the reasonable use of the land or structure, as required by subparagraph 9.1.9 D.2.
- F. Section 9.1.11 requires that a Special Use Permit shall not be granted by the Zoning Board of Appeals unless the public hearing record and written application demonstrate the following:
- (1) That the Special Use is necessary for the public convenience at that location;
  - (2) That the Special Use is so designed, located, and proposed as to be operated so that it will not be injurious to the DISTRICT in which it shall be located or otherwise detrimental to the public welfare except that in the CR, AG-1, and AG-2 DISTRICTS the following additional criteria shall apply:
    - a. The property is either BEST PRIME FARMLAND and the property with proposed improvements in WELL SUITED OVERALL or the property is not BEST PRIME FARMLAND and the property with proposed improvements is SUITED OVERALL.
    - b. The existing public services are available to support the proposed SPECIAL USE effectively and safely without undue public expense.
    - c. The existing public infrastructure together with proposed improvements is adequate to support the proposed development effectively and safely without undue public expense.
  - (3) That the Special Use conforms to the applicable regulations and standards of and preserves the essential character of the DISTRICT in which it shall be located, except where such regulations and standards are modified by Section 6.
  - (4) That the Special Use is in harmony with the general purpose and intent of this ordinance.
  - (5) That in the case of an existing NONCONFORMING USE, it will make such USE more compatible with its surroundings.
- G. Paragraph 9.1.11.D.2. states that in granting any SPECIAL USE permit, the BOARD may prescribe SPECIAL CONDITIONS as to appropriate conditions and safeguards in conformity with the Ordinance. Violation of such SPECIAL CONDITIONS when made a party of the terms under which the SPECIAL USE permit is granted, shall be deemed a violation of this Ordinance and punishable under this Ordinance.

**Cases 995-S-20 & 996-V-20 - REVISED *REVISED DRAFT 05/27/21***

Page 10 of 29

- H. Regarding the proposed variance:
- (1) Part A: The requirement for the maximum sign face area of an off-premises freestanding sign is established in Section 7.3.5 of the Zoning Ordinance as 300 square feet.
  - (2) Part B: The requirement for the maximum height of an off-premises freestanding sign is established in Section 7.3.5 of the Zoning Ordinance as 30 feet.
  - (3) Part C: The requirement for the maximum allowed one sign per frontage is established in Section 7.3.5 of the Zoning Ordinance.
  - (4) Part D: The minimum requirements for setback from street centerline and front yard along a State highway are established in Section 4.3.2. of the Zoning Ordinance as 85 feet and 35 feet, respectively.

***GENERALLY REGARDING WHETHER THE SPECIAL USE IS NECESSARY FOR THE PUBLIC CONVENIENCE AT THIS LOCATION***

7. Generally regarding the *Zoning Ordinance* requirement that the proposed Special Use is necessary for the public convenience at this location:
- A. The Petitioner has testified on the application, **“According to initial market feedback I have had, local businesses would like to advertise in this area to direct traffic to local communities leading to local communities thriving. This being the corner of Interstate 72 and Highway 47, it is a great location.”**
  - B. All four quadrants of the I-72/Route 47 interchange were zoned for B-3 Highway Business with the adoption of the Zoning Ordinance on October 10, 1973.
    - (1) The subject property is in the northwest quadrant of this interchange.
  - C. Potential clients for advertising on the off-premises signs would likely come from businesses in Champaign-Urbana and other nearby communities.

***GENERALLY REGARDING WHETHER THE SPECIAL USE WILL BE INJURIOUS TO THE DISTRICT OR OTHERWISE INJURIOUS TO THE PUBLIC WELFARE***

8. Generally regarding the *Zoning Ordinance* requirement that the proposed Special Use be designed, located, and operated so that it will not be injurious to the District in which it shall be located, or otherwise detrimental to the public welfare:
- A. The Petitioner has testified on the application: **“Sign will not be detrimental to public welfare. Sign will be attractive, new and well maintained. Sign will have lumens designed to not provide any unnecessary light pollution. Vertical access to the sign will be locked down so only authorized personnel can access it.”**
  - B. Regarding surface drainage:
    - (1) The subject property is relatively flat, and generally drains to the south.
    - (2) The addition of the proposed billboard structure will not add impervious area to the development, and should therefore not impact drainage on the site.



**REVISED DRAFT 05/27/21 Cases 995-S-20 & 996-V-20 - REVISED**

- a. Per special condition G from approved Case 977-S-20, the petitioners must have a complete Storm Water Drainage Plan that conforms to the requirements of the Storm Water Management and Erosion Control Ordinance for Phase 2 of their self-storage warehouse buildings.
  - b. Special condition H from Case 977-S-20 states that the south 55 feet of the property must be reserved for a detention basin.
- (3) The Natural Resource Information Report received on July 27, 2020 from the Champaign County Soil and Water Conservation District includes the following:
- a. Soil on the subject property is 3.1 acres of 154A Flanagan silt loam, and 0.3-acre 152 Drummer silty clay loam. The Drummer soils are located in the southeast corner of the subject property.
    - (a) Soil limitations for small commercial buildings are “somewhat limited” in 154A Flanagan soils due to the depth to the saturation zone and shrink-swell potential. 152A Drummer soils are “very limited” due to ponding and the depth to the saturation zone.
    - (b) 152A Drummer soils are hydric soils, which by definition have seasonal high water at or near the soil surface and/or have potential flooding or ponding problems.
  - b. The proposed billboard structure should not have any impact on the Natural Resource Information Report from Case 977-S-20.
- C. Regarding traffic in the subject property area:
- (1) The subject property is located west of IL-47 about 300 feet north of the I-72 interchange with IL-47.
    - a. County Road 1675N is a two-lane township road that is approximately 18 feet wide with two feet of gravel on each side.
    - b. IL-47 is a two-lane marked State highway approximately 24 feet wide with 4 feet paved shoulders.
  - (2) The proposed billboard should not impact visibility at the intersection of CR 1675N and IL-47 because the lowest face of the billboard will be ~~13~~ 13.5 feet off the ground and would be located outside the visibility triangle.
  - (3) The proposed billboard structure should not impact traffic.
  - (4) The Scott Township Road Commissioner has been notified of this case and no comments have been received.
- D. Regarding fire protection, the subject property is located approximately 2.2 road miles northeast of the Seymour Fire Department station. The Fire Chief was notified of this case and no comments have been received.
- E. No part of the subject property is located within a mapped floodplain.

**Cases 995-S-20 & 996-V-20 - REVISED *REVISED DRAFT 05/27/21***

Page 12 of 29

- F. The subject property is considered BEST PRIME FARMLAND. The soil on the subject property consists of 152A Drummer silty clay loam and 154A Flanagan silt loam, and has an average LE of 100.
- (1) Approximately 2.9 acres of the 3.36-acre subject property will be converted from agricultural production to construct the proposed self-storage warehouses approved in Cases 977-S-20 and 979-V-20.
  - (2) All four quadrants around the I-72 interchange at I-47 were zoned B-3 Highway Business with the adoption of the Zoning Ordinance on October 10, 1973. The usual findings for a Special Use Permit regarding Best Prime Farmland only apply in CR, AG-1, and AG-2 districts, so the Board does not have to make findings regarding whether the proposed uses is “WELL SUITED OVERALL”, and whether existing public infrastructure and services are available to support the proposed development.
  - (3) The proposed billboard structure will not remove additional land from agricultural production.
- G. Regarding outdoor lighting on the subject property:
- (1) The petitioner stated on the application for Case 995-S-20, “Sign will have lumens designed to not provide any unnecessary light pollution.”
  - (2) The petitioner indicated on the application for Case 977-S-20 for the self-storage warehouse units that “site will have minimum lights to not provide any unnecessary light pollution to the one house that is approximately 300 feet from the site.”
  - (3) A special condition has been added regarding any outdoor lighting for the Special Use Permit area.
- H. Regarding wastewater treatment and disposal on the subject property:
- (1) The petitioner plans to install a caretaker’s residence that would require a new septic system in a later phase of the self-storage warehouse development.
  - (2) There should be no impacts on the septic system configuration or location due to the proposed billboard structure, which would be located on the other side of the property from the septic system.
- I. Other than as reviewed in this Summary of Evidence, there is no evidence to suggest that the proposed Special Use will generate either nuisance conditions such as odor, noise, vibration, glare, heat, dust, electromagnetic fields or public safety hazards such as fire, explosion, or toxic materials release, that are in excess of those lawfully permitted and customarily associated with other uses permitted in the zoning district.

***GENERALLY REGARDING WHETHER THE SPECIAL USE CONFORMS TO APPLICABLE REGULATIONS AND STANDARDS AND PRESERVES THE ESSENTIAL CHARACTER OF THE DISTRICT***

9. Generally regarding the *Zoning Ordinance* requirement that the proposed Special Use conform to all applicable regulations and standards and preserve the essential character of the District in

**REVISED DRAFT 05/27/21 Cases 995-S-20 & 996-V-20 - REVISED**

which it shall be located, except where such regulations and standards are modified by Section 6 of the Ordinance:

- A. The Petitioner has testified on the application: **“Yes.”**
- B. Regarding compliance with the *Zoning Ordinance*:
  - (1) Self-Storage Warehouses providing heat and utilities to individual units are authorized by-right in the B-4 and I-1 Zoning DISTRICTS. They are authorized with a Special Use Permit in the B-1, B-3, and B-5 Zoning DISTRICTS.
  - (2) “Off-premises signs” are authorized by-right in the B-3 Highway Business Zoning District.
- C. Regarding parking on the subject property for the proposed billboard structure:
  - (1) The proposed billboard structure should not impact the number or location of the parking spaces approved for the self-storage warehouses in Cases 977-S-20 and 979-V-20.
- D. Regarding compliance with the *Storm Water Management and Erosion Control Ordinance*:
  - (1) The self-storage warehouses approved in Cases 977-S-20 and 979-V-20 are not exempt from the SWMEC Ordinance, and a Storm Water Drainage Plan (SWDP) will be required for Phase 2 of that development.
    - a. The proposed billboard structure will add no new requirements related to the SWMEC Ordinance.
- E. Regarding the *Special Flood Hazard Areas Ordinance*, no portion of the subject property is located within the mapped floodplain.
- F. Regarding the *Subdivision Regulations*, the subject property is located in the County’s subdivision jurisdiction and the subject property is in compliance.
- G. Regarding the requirement that the Special Use preserve the essential character of the B-3 Highway Business Zoning District:
  - (1) “Self-storage Warehouses providing heat and utilities to individual units” are allowed with a Special Use Permit in the B-3 Highway Business Zoning District.
  - (2) “Off-premises signs” are authorized by-right in the B-3 Highway Business Zoning District.
- H. The proposed billboard structure is exempt from accessibility requirements per Section 2.3.4 of the Illinois Accessibility Code.

**GENERALLY REGARDING WHETHER THE SPECIAL USE IS IN HARMONY WITH THE GENERAL PURPOSE AND INTENT OF THE ORDINANCE**

- 10. Regarding the *Zoning Ordinance* requirement that the proposed Special Use be in harmony with the general intent and purpose of the Ordinance:
  - A. Section 5.2: Table of Authorized Principal Uses states:
    - (1) “Self-storage Warehouses providing heat and utilities to individual units” can be established with a Special Use Permit in the B-3 Highway Business Zoning District.

**Cases 995-S-20 & 996-V-20 - REVISED *REVISED DRAFT 05/27/21***

Page 14 of 29

- (2) “Off-premises signs” are authorized by-right in the B-3 Highway Business Zoning District.

B. Regarding whether the proposed Special Use Permit is in harmony with the general intent of the Zoning Ordinance:

- (1) Subsection 5.1.11 of the Ordinance states, “The B-3 Highway Business DISTRICT is intended to provide areas for commercial establishments which primarily serve the needs of motorists and are intended for application only adjacent to major thoroughfares in the COUNTY.”
- (2) The types of uses authorized in the B-3 District are in fact the types of uses that have been determined to be acceptable in the B-3 District. Uses authorized by Special Use Permit are acceptable uses in the district provided that they are determined by the ZBA to meet the criteria for Special Use Permits established in paragraph 9.1.11 B. of the Ordinance.

C. Regarding whether the proposed Special Use Permit is in harmony with the general purpose of the Zoning Ordinance:

- (1) Paragraph 2.0 (a) of the Ordinance states that one purpose of the zoning regulations and standards that have been adopted and established is to secure adequate light, pure air, and safety from fire and other dangers.
  - a. This purpose is directly related to the limits on building coverage and the minimum yard requirements in the Ordinance and the proposed site plan appears to be in compliance with those requirements.
- (2) Paragraph 2.0 (b) of the Ordinance states that one purpose of the zoning regulations and standards that have been adopted and established is to conserve the value of land, BUILDINGS, and STRUCTURES throughout the COUNTY.
  - a. It is not clear whether the proposed special use will have any impact on the value of nearby properties without a formal real estate appraisal, which has not been requested nor provided, and so any discussion of values is necessarily general.
- (3) Paragraph 2.0 (c) of the Ordinance states that one purpose of the zoning regulations and standards that have been adopted and established is to lessen and avoid congestion in the public streets.
  - a. The proposed billboard structure will not impact traffic volumes.
- (4) Paragraph 2.0 (d) of the Ordinance states that one purpose of the zoning regulations and standards that have been adopted and established is to lessen and avoid hazards to persons and damage to property resulting from the accumulation of runoff of storm or flood waters.
  - a. The self-storage warehouses approved in Cases 977-S-20 and 979-V-20 are not exempt from the SWMEC Ordinance, and a Storm Water Drainage Plan (SWDP) will be required for Phase 2 of that development.
    - (a) The proposed billboard structure will add no new requirements related to the SWMEC Ordinance.

**REVISED DRAFT 05/27/21 Cases 995-S-20 & 996-V-20 - REVISED**

Page 15 of 29

- (5) Paragraph 2.0 (e) of the Ordinance states that one purpose of the zoning regulations and standards that have been adopted and established is to promote the public health, safety, comfort, morals, and general welfare.
  - a. Regarding public safety, this purpose is similar to the purpose established in paragraph 2.0 (a) and is in harmony to the same degree.
  - b. Regarding public comfort and general welfare, this purpose is similar to the purpose of conserving property values established in paragraph 2.0 (b) and is in harmony to the same degree.
  
- (6) Paragraph 2.0 (f) states that one purpose of the Ordinance is regulating and limiting the height and bulk of BUILDINGS and STRUCTURES hereafter to be erected; and paragraph 2.0 (g) states that one purpose is establishing, regulating, and limiting the BUILDING or SETBACK lines on or along any STREET, trafficway, drive or parkway; and paragraph 2.0 (h) states that one purpose is regulating and limiting the intensity of the USE of LOT AREAS, and regulating and determining the area of OPEN SPACES within and surrounding BUILDINGS and STRUCTURES.
  - a. These three purposes are directly related to the limits on building height and building coverage and the minimum setback and yard requirements in the Ordinance and the proposed site plan appears to be in compliance with those limits if the variances in related Case 996-V-20 are approved.
  
- (7) Paragraph 2.0 (i) of the Ordinance states that one purpose of the Ordinance is classifying, regulating, and restricting the location of trades and industries and the location of BUILDINGS, STRUCTURES, and land designed for specified industrial, residential, and other land USES; and paragraph 2.0 (j) states that one purpose is dividing the entire COUNTY into DISTRICTS of such number, shape, area, and such different classes according to the USE of land, BUILDINGS, and STRUCTURES, intensity of the USE of LOT AREA, area of OPEN SPACES, and other classification as may be deemed best suited to carry out the purpose of the ordinance; and paragraph 2.0 (k) states that one purpose is fixing regulations and standards to which BUILDINGS, STRUCTURES, or USES therein shall conform; and paragraph 2.0 (l) states that one purpose is prohibiting USES, BUILDINGS, OR STRUCTURES incompatible with the character of such DISTRICT.
  - a. Harmony with these four purposes requires that the special conditions of approval sufficiently mitigate or minimize any incompatibilities between the proposed Special Use Permit and adjacent uses, and that the special conditions adequately mitigate any problematic conditions.
  
- (8) Paragraph 2.0 (m) of the Ordinance states that one purpose of the zoning regulations and standards that have been adopted and established is to prevent additions to and alteration or remodeling of existing buildings, structures, or uses in such a way as to avoid the restrictions and limitations lawfully imposed under this ordinance.
  - a. This purpose is directly related to maintaining compliance with the Zoning Ordinance requirements for the District and the specific types of uses and the proposed Special Use will have to be conducted in compliance with those requirements.

**Cases 995-S-20 & 996-V-20 - REVISED *REVISED DRAFT 05/27/21***

Page 16 of 29

- (9) Paragraph 2.0 (n) of the Ordinance states that one purpose of the zoning regulations and standards that have been adopted and established is to protect the most productive agricultural lands from haphazard and unplanned intrusions of urban uses.
  - a. The proposed uses do not meet the definition of either “urban development” or “urban land use” as defined in the Appendix to Volume 2 of the Champaign County Land Resource Management Plan.
  
- (10) Paragraph 2.0 (o) of the Ordinance states that one purpose of the zoning regulations and standards that have been adopted and established is to protect natural features such as forested areas and watercourses.
  - a. The subject property does not contain any natural features.
  
- (11) Paragraph 2.0 (p) of the Ordinance states that one purpose of the zoning regulations and standards that have been adopted and established is to encourage the compact development of urban areas to minimize the cost of development of public utilities and public transportation facilities.
  - a. The proposed Special Use does not meet the definition of either “urban development” or “urban land use” as defined in the Appendix to Volume 2 of the Champaign County Land Resource Management Plan.
  
- (12) Paragraph 2.0 (q) of the Ordinance states that one purpose of the zoning regulations and standards that have been adopted and established is to encourage the preservation of agricultural belts surrounding urban areas, to retain the agricultural nature of the County, and the individual character of existing communities.
  - a. The proposed billboard structure would not remove additional land from agricultural production.
  
  - b. The closest incorporated community to the subject property is the Village of Bondville, 2 miles away.
  
- (13) Paragraph 2.0 (r) of the Ordinance states that one purpose of the zoning regulations and standards that have been adopted and established is to provide for the safe and efficient development of renewable energy sources in those parts of the COUNTY that are most suited to their development.
  - a. The proposed Special Use will not hinder the development of renewable energy sources.

***GENERALLY REGARDING WHETHER THE SPECIAL USE IS AN EXISTING NONCONFORMING USE***

11. Regarding the *Zoning Ordinance* requirement that in the case of an existing NONCONFORMING USE the granting of the Special Use Permit will make the use more compatible with its surroundings:
  - A. The Petitioner has testified on the application: “NA”
  
  - B. The existing use on the property is agriculture.

**REVISED DRAFT 05/27/21 Cases 995-S-20 & 996-V-20 - REVISED**

Page 17 of 29

**RELATED TO THE VARIANCE, GENERALLY REGARDING SPECIAL CONDITIONS THAT MAY BE PRESENT**

12. Generally regarding the Zoning Ordinance requirement of a finding that special conditions and circumstances exist which are peculiar to the land or structure involved that are not applicable to other similarly situated land or structures elsewhere in the same district:
- A. The Petitioner has testified on the application, **“Sign advertisement will be good for the local community. This is a very busy intersection of Interstate 72 and IL 47 and sign advertisement in this location is going to lead to local businesses prospering. I have had local businesses approach me about this, wanting to advertise on the sign to direct the traffic to local communities and businesses.”**
- B. The subject property is surrounded by land in agricultural production and one residence that is approximately 775 feet west of the proposed billboard structure.
- (1) The proposed billboard would be located at the farthest point possible on the subject property from the adjacent residence.
- C. The subject property fronts one township road (CR 1675N), one State route (IL-47/CR 300E), and is less than one-quarter mile from the Interstate 72 interchange at IL-47.
- D. Regarding Part A of the proposed variance, for having a total sign face area of ~~1,152~~ 589 square feet in lieu of the maximum allowed 300 square feet:
- (1) Of 34 zoning cases for sign variances since the adoption of the Zoning Ordinance on October 10, 1973, this is the only variance request for area of the sign face for an off-premises sign.
- a. Of the 34 cases, there have been 21 variance requests for sign face area, and this is the ~~fourth~~ fifth largest variance by percentage and the second largest variance by sign face area.
- E. Regarding Part B of the proposed variance, for a height of ~~37~~ 35.5 feet in lieu of the maximum allowed 30 feet:
- (1) The space between the ground and the lowest billboard will be ~~13~~ 13.5 feet.
- (2) Of the 14 variance requests for sign height since adoption of the Zoning Ordinance, the current request is the eighth largest by percentage variance and the sixth largest variance by actual height, with the tallest being 65 feet.
- ~~F. Regarding Part C of the proposed variance, for authorizing four off-premises freestanding signs on one sign structure in addition to one on-premises freestanding sign along the same frontage, in lieu of the maximum authorized one sign per frontage:~~
- ~~(1) Of the 7 variance requests for number of signs since adoption of the Zoning Ordinance, the current request is the largest by percentage variance and the second largest variance by actual number of signs beyond the maximum allowed.~~
- ~~(2) The petitioner installed an on-premises advertising sign at some point after approval of cases 977-S-20 and 979-V-20 without a permit. It is unknown if this sign is temporary or if it would need a permit to remain onsite. A special condition has been added to ensure compliance with the Zoning Ordinance.~~

**Cases 995-S-20 & 996-V-20 - REVISED REVISED DRAFT 05/27/21**

Page 18 of 29

- E.** Regarding Part **C** of the proposed variance, for four off-premises freestanding signs on one sign structure with a setback of ~~64~~ **72.5** feet from the street centerline of IL Route 47 and a front yard of ~~23~~ **31.5** feet, in lieu of the minimum required setback of 85 feet and front yard of 35 feet along a State highway:
- (1) Of the 2 variance requests for setback of a sign since adoption of the Zoning Ordinance, the current request is the smaller of the two by percentage variance and also the smaller variance by actual setback.
  - (2) Of the 3 variance requests for front yard between a road right-of-way and a sign since adoption of the Zoning Ordinance, the current request is the third largest by percentage variance and the smallest variance by actual setback.

**RELATED TO THE VARIANCE, GENERALLY REGARDING ANY PRACTICAL DIFFICULTIES OR HARDSHIPS RELATED TO CARRYING OUT THE STRICT LETTER OF THE ORDINANCE**

13. Generally regarding the Zoning Ordinance requirement of a finding that practical difficulties or hardships related to carrying out the strict letter of the regulations sought to be varied prevent reasonable and otherwise permitted use of the land or structures or construction on the lot:
- A. The Petitioner has testified on the application, **“The ability to provide the upfront investment of the structure would not be feasible with the regulations of 1 face. Proceeding with the variance and the 2 faces would allow for the upfront investment.”**
  - B. Regarding Part A of the proposed variance, for having a total sign face area of ~~1,152~~ **589** square feet in lieu of the maximum allowed 300 square feet:
    - (1) Without the proposed variance, the petitioner would have to reduce the total sign face area to 300 square feet, which is the maximum allowed in the Ordinance.
  - C. Regarding Part B of the proposed variance, for a height of ~~37~~ **35.5** feet in lieu of the maximum allowed 30 feet:
    - (1) Without the proposed variance, the petitioner would have to reduce the sign height to 30 feet, which is the maximum allowed in the Ordinance.
  - ~~D. Regarding Part C of the proposed variance, for authorizing four off-premises freestanding signs on one sign structure in addition to one on-premises freestanding sign along the same frontage, in lieu of the maximum authorized one sign per frontage:
 
    - (1) Without the proposed variance, the petitioner would have to choose between advertising his own business along the IL-47 corridor frontage and advertising for other businesses on that frontage.~~
  - E. Regarding Part **C** of the proposed variance, for four off-premises freestanding signs on one sign structure with a setback of ~~64~~ **72.5** feet from the street centerline of IL Route 47 and a front yard of ~~23~~ **31.5** feet, in lieu of the minimum required setback of 85 feet and front yard of 35 feet along a State highway:
    - (1) Without the proposed variance, the billboard structure could not be located along the IL-47 frontage without reducing the building area.



**REVISED DRAFT 05/27/21 Cases 995-S-20 & 996-V-20 - REVISED**

**RELATED TO THE VARIANCE, GENERALLY PERTAINING TO WHETHER OR NOT THE PRACTICAL DIFFICULTIES OR HARDSHIPS RESULT FROM THE ACTIONS OF THE APPLICANT**

14. Generally regarding the Zoning Ordinance requirement for a finding that the special conditions, circumstances, hardships, or practical difficulties do not result from the actions of the Applicant:
  - A. The Petitioner has testified on the application, **“No.”**
  - B. The Petitioner is aware of the proposed billboard structure not meeting Zoning Ordinance requirements, and has not yet made the upfront investment.

**GENERALLY PERTAINING TO WHETHER OR NOT THE VARIANCE IS IN HARMONY WITH THE GENERAL PURPOSE AND INTENT OF THE ORDINANCE**

15. Generally regarding the Zoning Ordinance requirement for a finding that the granting of the variance is in harmony with the general purpose and intent of the Ordinance:
  - A. The Petitioner has testified on the application, **“Granting this variance will be harmonic with the use of the land for storage.”**
  - B. Regarding Part A of the proposed variance, for having a total sign face area of ~~1,152~~ 589 square feet in lieu of the maximum allowed 300 square feet: the requested variance is ~~384~~ 196% of the maximum allowed, for a variance of ~~284~~ 96%.
    - (1) The Zoning Ordinance does not clearly state the considerations that underlie the maximum sign face area. In Zoning Case 752-AT-91 regarding sign regulations (withdrawn), the only public purpose that was suggested for sign regulations was to minimize the detrimental aesthetics of overly large signs, particularly in areas expected to have a high density of signs, while recognizing that sign size is related to the business need to attract customers that are driving by and the general relationship that the higher the speed limit the larger the sign area must be to be readable to passing customers.
  - C. Regarding Part B of the proposed variance, for a height of ~~37~~ 35.5 feet in lieu of the maximum allowed 30 feet: the requested variance is ~~123~~ 118% of the maximum allowed, for a variance of ~~23~~ 18%.
    - (1) The Zoning Ordinance does not clearly state the considerations that underlie the height requirement. Presumably, the height limitation is to minimize visual clutter, to promote traffic safety, and to minimize danger to low-flying aircraft.
    - (2) The proposed off-premises sign structure is ~~8~~ 9.5 feet lower than the maximum allowed height of 45 feet for an on-premises sign structure in the B-3 zoning district.
  - ~~D. — Regarding Part C of the proposed variance, for authorizing four off-premises freestanding signs on one sign structure in addition to one on-premises freestanding sign along the same frontage, in lieu of the maximum authorized one sign per frontage: the requested variance is 400% of the maximum allowed, for a variance of 300%.
 
    - (1) — The Zoning Ordinance does not clearly state the considerations that underlie the requirement limiting the number of signs on one frontage. Presumably, the purpose of limiting the number of signs along one frontage is to minimize visual clutter and to promote traffic safety.~~

**Cases 995-S-20 & 996-V-20 - REVISED REVISED DRAFT 05/27/21**

Page 20 of 29

- D. Regarding Part C of the proposed variance, for four off-premises freestanding signs on one sign structure with a setback of ~~64~~ 72.5 feet from the street centerline of IL Route 47 and a front yard of ~~23~~ 31.5 feet, in lieu of the minimum required setback of 85 feet and front yard of 35 feet along a State highway: the requested variance for setback is ~~75~~ 85.2% of the minimum required, for a variance of ~~25~~ 14.8%; the requested variance for front yard is ~~65.7~~ 90% of the minimum required, for a variance of ~~34.3~~ 10%.
- (1) The Zoning Ordinance does not clearly state the considerations that underlie the minimum front yard and setback requirements. Presumably, the minimums are intended to ensure the following:
- a. Adequate separation from roads. The IL-47 right-of-way at the southwest corner of the subject property is wider as it approaches the interchange at I-72 to the south, with a 65-foot wide half-right-of-way.
  - b. Allow adequate area for road expansion and right-of-way acquisition. There are no known expansion plans for IL-47 at this location.
  - c. Parking, where applicable. The proposed variances would not impact required parking for the self-storage warehouses.
- E. The requested variance is not prohibited by the *Zoning Ordinance*.

**GENERALLY PERTAINING TO THE EFFECTS OF THE REQUESTED VARIANCE ON THE NEIGHBORHOOD AND THE PUBLIC HEALTH, SAFETY, AND WELFARE**

16. Generally regarding the Zoning Ordinance requirement for a finding that the granting of the variance will not be injurious to the neighborhood, or otherwise detrimental to the public health, safety, or welfare:
- A. The Petitioner has testified on the application: **“Approving this variance would not be injurious to the neighborhood nor detrimental to public health, safety, or welfare.”**
  - B. The Scott Township Road Commissioner has been notified of this variance and no comments have been received.
  - C. The Seymour Fire Department has been notified of this variance. ~~and no comments have been received~~ Regarding the proposed sign face size of 12 feet by 24 feet, at the March 25, 2021, ZBA meeting, Assistant Fire Chief Jim Randol spoke on behalf of the Seymour Fire Department, stating it is their feeling that this is a safety issue along Route 47. He said they get called to the overpass area for accidents, and they just feel that this sign is one more thing to add to the accident potential. He said that they feel the sign is just too large for the area, no matter if it is facing Route 47 or CR 1675N. He said that it is a huge sign to have at a busy intersection where traffic is sometimes running 70 mph over the overpass. He said they are not objecting to a sign being there, they are objecting to the size of this sign. He said he thinks if it was even half the size that is being proposed it might be okay, but at this point they object to the size of it. He said it is both the size and having four different signs to read that make it a distraction and a hazard at that location.
    - (1) The petitioner reduced the original proposed sign face size from 12 feet by 24 feet to 9.5 feet by 15.5 feet in part because the Seymour Fire District expressed

**REVISED DRAFT 05/27/21 Cases 995-S-20 & 996-V-20 - REVISED**

concerns about four 12 feet by 24 feet sign faces being a distraction and a safety concern at the proposed location.

(2) The petitioner revised the proposed clearance below the lowest billboard face to 13.5 feet in order to accommodate fire trucks and other high-profile vehicles.

D. Parts A ~~and C~~ of the variance will result in nearly ~~four times~~ twice the amount of visual clutter and detrimental aesthetics than would be allowed without the variance, but both sides of the proposed sign are not visible from any location.

E. No comments have been received for the proposed variance.

**GENERALLY REGARDING ANY OTHER JUSTIFICATION FOR THE VARIANCE**

17. Generally regarding any other circumstances that justify the Variance:

A. The Petitioner did not provide a response to this question.

**GENERALLY REGARDING PROPOSED SPECIAL CONDITIONS OF APPROVAL**

18. Regarding proposed special conditions of approval:

A. **The Zoning Administrator shall not authorize a Zoning Use Permit or a Zoning Compliance Certificate until the petitioner has demonstrated that any new or proposed exterior lighting on the subject property will comply with the lighting requirements of Section 6.1.2.**

The special condition stated above is required to ensure the following:

**That the proposed uses are in compliance with the Zoning Ordinance.**

B. **Regarding the existing on-premises advertising sign, within 30 days of approval of Zoning Cases 995-S-20 and 996-V-20, the petitioner must either:**

**(1) Provide written verification to the P&Z Department that the sign is temporary and will be removed with 14 days of completing construction of the first self-storage building, or**

**(2) Apply for a Zoning Use Permit for the permanent sign, pay the corresponding fee, and receive permit approval, or remove the sign.**

The special condition stated above is required to ensure the following:

**That all structures on the property comply with the Zoning Ordinance.**

C. **Any future sale of the subject property may be subject to the Illinois Plat Act (765 ILCS 205/0.01 et seq.) or the Champaign County Subdivision Regulations; or the subdivision regulations of a municipality that has jurisdiction within one and one-half miles of the corporate limits.**

The special condition stated above is required to ensure the following:

**That the subject property complies with the Zoning Ordinance.**

**Cases 995-S-20 & 996-V-20 - REVISED *REVISED DRAFT 05/27/21***

Page 22 of 29

**DOCUMENTS OF RECORD**

1. Applications for Special Use Permit and Variance received December 23, 2020, with attachments:
  - Site Plan sheet prepared by Hartke Engineering & Surveying dated September 28, 2020
  - Plan View Sheet prepared by RMG Outdoor Inc dated November 20, 2020
  
2. Preliminary Memorandum dated January 20, 2021, with attachments:
  - A Case Maps (Location, Land Use, Zoning)
  - B Site Plan sheet prepared by Hartke Engineering & Surveying dated September 28, 2020
  - C Plan View Sheet prepared by RMG Outdoor Inc dated November 2, 2020
  - D Site Visit Photos taken January 15, 2021
  - E Preliminary Summary of Evidence, Summary Draft Findings of Fact, and Final Determination dated January 28, 2021
  
3. Supplemental Memorandum #1 dated March 8, 2021, with attachments:
  - A Email from Mr. Kimball received on February 12, 2021, with attachments:
    - Photo rendering of 12 x 24 billboard created by RMG Outdoor
    - Example of existing double 12 x 24 billboard along IL 40
    - Example of existing double 12 x 24 billboard near Mt. Vernon
  - B Email from Mr. Kimball received on February 26, 2021, with attachment: sign sizes matrix
  - C Existing sign and pole with dimensions created by P&Z Staff on February 24, 2021
  - D 2020 aerial photo showing the proposed sign location created by P&Z Staff on February 24, 2021
  - E 3D video simulation received March 3, 2021
  - F Screenshots of 3D video created by P&Z Staff on March 4, 2021
  
4. Supplemental Memorandum #2 dated May 18, 2021, with attachments:
  - A Email string between Mr. Kimball and John Hall dated April 14, 2021, with attachment:
    - Revised Plan and Elevation View of the billboard received April 14, 2021
  - B Cases 995-S-20 and 996-V-20 Revised Summary of Evidence, Draft Summary Finding of Fact, and Final Determination dated May 27, 2021

**REVISED DRAFT 05/27/21 Cases 995-S-20 & 996-V-20 - REVISED**

Page 23 of 29

**SUMMARY DRAFT FINDINGS OF FACT FOR CASE 995-S-20**

From the documents of record and the testimony and exhibits received at the public hearing for zoning case **995-S-20** held on **January 28, 2021, March 25, 2021, and May 27, 2021**, the Zoning Board of Appeals of Champaign County finds that:

1. The requested Special Use Permit **{IS / IS NOT}** necessary for the public convenience at this location because:
  - a. *All four quadrants of the I-72/Route 47 interchange were zoned for B-3 Highway Business with the adoption of the Zoning Ordinance on October 10, 1973.*
  - b. *Potential clients for advertising on the off-premises signs would likely come from businesses in Champaign-Urbana and other nearby communities.*
  
2. The requested Special Use Permit **{SUBJECT TO THE SPECIAL CONDITIONS IMPOSED HEREIN}** is so designed, located, and proposed to be operated so that it **{WILL NOT / WILL}** be injurious to the district in which it shall be located or otherwise detrimental to the public health, safety, and welfare because:
  - a. The street has **{ADEQUATE / INADEQUATE}** traffic capacity and the entrance location has **{ADEQUATE / INADEQUATE}** visibility because: *the proposed billboard should not impact visibility at the intersection of CR 1675N and IL-47 because the lowest face of the billboard will be ~~13~~ 13.5 feet off the ground and would be located outside the visibility triangle.*
  - b. Emergency services availability is **{ADEQUATE / INADEQUATE}** **{because\*}**: *the billboard structure will present no additional demand on emergency services availability beyond that for the self-storage warehouses approved in Cases 977-S-20 and 979-V-20.*
  - c. The Special Use **{WILL / WILL NOT}** be compatible with adjacent uses **{because\*}**: *the subject property is surrounded on three sides by land in agricultural production; there is one residence approximately 775 feet west of the proposed sign structure; and the sign will be visible from adjacent IL-47 and to a lesser extent I-72.*
  - d. Surface and subsurface drainage will be **{ADEQUATE / INADEQUATE}** **{because\*}**: *the petitioners must complete a Storm Water Drainage Plan and drainage basin for the self-storage warehouses approved in Cases 977-S-20 and 979-V-20, and the sign structure will not impact drainage on the property.*
  - e. Public safety will be **{ADEQUATE / INADEQUATE}** **{because\*}**: *adequate public safety was established for the self-storage warehouses approved in Cases 977-S-20 and 979-V-20; the proposed sign structure will have lighting designed to minimize light pollution, and vertical access to the sign will be locked down to all except authorized personnel.*
  - f. The provisions for parking will be **{ADEQUATE / INADEQUATE}** **{because\*}**: *adequate parking was established for the self-storage warehouses approved in Cases 977-S-20 and 979-V-20, and the proposed sign structure has no parking requirements.*

\* The Board may include other relevant considerations as necessary or desirable in each case.

\* The Board may include additional justification if desired, but it is not required.

**Cases 995-S-20 & 996-V-20 - REVISED REVISED DRAFT 05/27/21**

Page 24 of 29

- 3a. The requested Special Use Permit *{SUBJECT TO THE SPECIAL CONDITIONS IMPOSED HEREIN} {DOES / DOES NOT}* conform to the applicable regulations and standards of the DISTRICT in which it is located.
- 3b. The requested Special Use Permit *{SUBJECT TO THE SPECIAL CONDITIONS IMPOSED HEREIN} {DOES / DOES NOT}* preserve the essential character of the DISTRICT in which it is located because:
  - a. The Special Use will be designed to *{CONFORM / NOT CONFORM}* to all relevant County ordinances and codes.
  - b. The Special Use *{WILL / WILL NOT}* be compatible with adjacent uses.
  - c. Public safety will be *{ADEQUATE / INADEQUATE}*.
4. The requested Special Use Permit *{SUBJECT TO THE SPECIAL CONDITIONS IMPOSED HEREIN} {IS / IS NOT}* in harmony with the general purpose and intent of the Ordinance because:
  - a. The Special Use is authorized in the District.
  - b. The requested Special Use Permit *{IS / IS NOT}* necessary for the public convenience at this location.
  - c. The requested Special Use Permit *{SUBJECT TO THE SPECIAL CONDITIONS IMPOSED HEREIN}* is so designed, located, and proposed to be operated so that it *{WILL / WILL NOT}* be injurious to the district in which it shall be located or otherwise detrimental to the public health, safety, and welfare.
  - d. The requested Special Use Permit *{SUBJECT TO THE SPECIAL CONDITIONS IMPOSED HEREIN} {DOES / DOES NOT}* preserve the essential character of the DISTRICT in which it is located.
5. The requested Special Use *IS NOT* an existing nonconforming use.
6. ***{NO SPECIAL CONDITIONS ARE HEREBY IMPOSED / THE SPECIAL CONDITION IMPOSED HEREIN IS REQUIRED TO ENSURE COMPLIANCE WITH THE CRITERIA FOR SPECIAL USE PERMITS AND FOR THE PARTICULAR PURPOSES DESCRIBED BELOW:}***
  - A. **The Zoning Administrator shall not authorize a Zoning Use Permit or a Zoning Compliance Certificate until the petitioner has demonstrated that any new or proposed exterior lighting on the subject property will comply with the lighting requirements of Section 6.1.2.**

The special condition stated above is required to ensure the following:

**That the proposed uses are in compliance with the Zoning Ordinance.**

**REVISED DRAFT 05/27/21 Cases 995-S-20 & 996-V-20 - REVISED**

Page 25 of 29

- B. **Regarding the existing on-premises advertising sign, within 30 days of approval of Zoning Cases 995-S-20 and 996-V-20, the petitioner must either:**
- (1) **Provide written verification to the P&Z Department that the sign is temporary and will be removed with 14 days of completing construction of the first self-storage building, or**
  - (2) **Apply for a Zoning Use Permit for the permanent sign, pay the corresponding fee, and receive permit approval, or remove the sign.**

The special condition stated above is required to ensure the following:

**That all structures on the property comply with the Zoning Ordinance.**

- C. **Any future sale of the subject property may be subject to the Illinois Plat Act (765 ILCS 205/0.01 et seq.) or the Champaign County Subdivision Regulations; or the subdivision regulations of a municipality that has jurisdiction within one and one-half miles of the corporate limits.**

The special condition stated above is required to ensure the following:

**That the subject property complies with the Zoning Ordinance.**

**Cases 995-S-20 & 996-V-20 - REVISED REVISED DRAFT 05/27/21**

Page 26 of 29

**SUMMARY DRAFT FINDINGS OF FACT FOR CASE 996-V-20**

From the documents of record and the testimony and exhibits received at the public hearing for zoning case **996-V-20** held on **January 28, 2021**, **March 25, 2021, and May 27, 2021**, the Zoning Board of Appeals of Champaign County finds that:

1. Special conditions and circumstances *{DO / DO NOT}* exist which are peculiar to the land or structure involved, which are not applicable to other similarly situated land and structures elsewhere in the same district because:
  - a. *The subject property is surrounded by land in agricultural production and one residence that is approximately 775 feet west of the proposed billboard structure.*
  - b. *The proposed billboard would be located at the farthest point possible on the subject property from the adjacent residence.*
  - c. *The subject property fronts one township road (CR 1675N), one State route (IL-47/CR 300E), and is less than one-quarter mile from the Interstate 72 interchange at IL-47.*
2. Practical difficulties or hardships created by carrying out the strict letter of the regulations sought to be varied *{WILL / WILL NOT}* prevent reasonable or otherwise permitted use of the land or structure or construction because:
  - a. *Without the proposed variance for sign face area, the petitioner would have to reduce the total sign face area to 300 square feet, which is the minimum allowed by the Zoning Ordinance.*
  - b. *Without the proposed variance for sign height, the petitioner would have to reduce the sign height to 30 feet, which is the maximum allowed in the Ordinance.*
  - ~~c. *Without the proposed variance for more than one sign per frontage, the petitioner would have to choose between advertising his own business along the IL-47 corridor frontage and advertising for other businesses on that frontage.*~~
  - c. *Without the proposed variance for front yard and setback, the billboard structure could not be located along the IL-47 frontage without reducing the building area.*
3. The special conditions, circumstances, hardships, or practical difficulties *{DO / DO NOT}* result from actions of the applicant because:
  - a. *The Petitioner is aware of the proposed billboard structure not meeting Zoning Ordinance requirements, and has chosen not to purchase the sign structure until after determination of these zoning cases.*
4. The requested variance *{IS / IS NOT}* in harmony with the general purpose and intent of the Ordinance because:
  - a. *The proposed sign structure will not increase traffic volumes or impact parking onsite.*
  - b. *The proposed sign structure will not worsen storm water runoff or drainage.*



**REVISED DRAFT 05/27/21 Cases 995-S-20 & 996-V-20 - REVISED**

- c. *The proposed off-premises sign structure is **& 9.5** feet lower than the maximum allowed height of 45 feet for an on-premises sign structure in the B-3 zoning district.*
  - d. *The proposed sign structure will have four sign faces on one post rather than four separate sign structures.*
  - e. *Route 47 has an extra wide right-of-way which increases as it approaches the interchange with I-72. There are no known plans for road expansion or right-of-way acquisition.*
  - f. *Parts **A and C** of the variance will result in nearly **four-times-twice** the amount of visual clutter and detrimental aesthetics than would be allowed without the variance, **but both sides of the proposed sign are not visible from any location.***
5. The requested variance *{WILL / WILL NOT}* be injurious to the neighborhood or otherwise detrimental to the public health, safety, or welfare because:
- a. *No comments have been received from the Township Road Commissioner, ~~Fire Protection District~~, or community members.*
  - b. The petitioner reduced the original proposed sign face size from 12 feet by 24 feet to 9.5 feet by 15.5 feet in part because the Seymour Fire District expressed concerns about four 12 feet by 24 feet sign faces being a distraction and a safety concern at the proposed location, but both sides of the proposed sign are not visible from any location.*
  - c. The petitioner revised the proposed clearance below the lowest billboard face to 13.5 feet in order to accommodate fire trucks and other high-profile vehicles.*
  - d. Parts **A and C** of the variance will result in nearly **four-times-twice** the amount of visual clutter and detrimental aesthetics than would be allowed without the variance.*
6. The requested variance *{IS / IS NOT}* the minimum variation that will make possible the reasonable use of the land/structure *{because:}*
7. *{NO SPECIAL CONDITIONS ARE HEREBY IMPOSED / THE SPECIAL CONDITIONS IMPOSED HEREIN ARE REQUIRED FOR THE PARTICULAR PURPOSES DESCRIBED BELOW:}*

**Cases 995-S-20 & 996-V-20 - REVISED REVISED DRAFT 05/27/21**

Page 28 of 29

**FINAL DETERMINATION FOR CASE 995-S-20**

The Champaign County Zoning Board of Appeals finds that, based upon the application, testimony, and other evidence received in this case, the requirements of Section 9.1.11B. for approval *{HAVE/ HAVE NOT}* been met, and pursuant to the authority granted by Section 9.1.6 B. of the Champaign County Zoning Ordinance, determines that:

The Special Use requested in Case 995-S-20 is hereby *{GRANTED/ GRANTED WITH SPECIAL CONDITIONS / DENIED}* to the applicants, **Adam & Jodi Kimball**, to authorize the following:

**Authorize multiple principal structures on the same lot consisting of self-storage warehouses previously authorized in Cases 977-S-20 and 979-V-20 and a sign structure with four off-premises freestanding advertising signs as a Special Use in the B-3 Highway Business Zoning District, subject to approval of the variances requested in related Case 996-V-20.**

***{SUBJECT TO THE FOLLOWING SPECIAL CONDITIONS:}***

- A. The Zoning Administrator shall not authorize a Zoning Use Permit or a Zoning Compliance Certificate until the petitioner has demonstrated that any new or proposed exterior lighting on the subject property will comply with the lighting requirements of Section 6.1.2.**
- B. Regarding the existing on-premises advertising sign, within 30 days of approval of Zoning Cases 995-S-20 and 996-V-20, the petitioner must either:**
  - (1) Provide written verification to the P&Z Department that the sign is temporary and will be removed with 14 days of completing construction of the first self-storage building, or**
  - (2) Apply for a Zoning Use Permit for the permanent sign, pay the corresponding fee, and receive permit approval, or remove the sign.**
- C. Any future sale of the subject property may be subject to the Illinois Plat Act (765 ILCS 205/0.01 et seq.) or the Champaign County Subdivision Regulations; or the subdivision regulations of a municipality that has jurisdiction within one and one-half miles of the corporate limits.**

The foregoing is an accurate and complete record of the Findings and Determination of the Zoning Board of Appeals of Champaign County.

SIGNED:

ATTEST:

Ryan Elwell, Chair  
Champaign County Zoning Board of Appeals

Secretary to the Zoning Board of Appeals

Date

**REVISED DRAFT 05/27/21 Cases 995-S-20 & 996-V-20 - REVISED**

**FINAL DETERMINATION FOR CASE 996-V-20**

The Champaign County Zoning Board of Appeals finds that, based upon the application, testimony, and other evidence received in this case, that the requirements for approval in Section 9.1.9.C *{HAVE/ HAVE NOT}* been met, and pursuant to the authority granted by Section 9.1.6.B of the Champaign County Zoning Ordinance, the Zoning Board of Appeals of Champaign County determines that:

The Variance requested in Case **996-V-20** is hereby *{GRANTED/ GRANTED WITH SPECIAL CONDITIONS / DENIED}* to the applicants, **Adam & Jodi Kimball**, to authorize the following:

**Authorize the following variances for the Special Use Permit requested in related Zoning Case 995-S-20 for proposed off-premises signs in the B-3 Highway Business Zoning District, per Section 7.3.5 of the Zoning Ordinance:**

**Part A:** A variance for four off-premises freestanding advertising signs on one sign structure on one frontage that total ~~1,152~~ 589 square feet in sign face area in lieu of the maximum allowed one off-premises sign per frontage that totals 300 square feet in sign face area.

**Part B:** A variance for four off-premises freestanding advertising signs on one sign structure with a maximum height of ~~37~~ 35.5 feet in lieu of the maximum allowed 30 feet.

~~**Part C:** A variance for four off-premises freestanding advertising signs on one sign structure in addition to an on-premises sign along the same IL Route 47 frontage, in lieu of the maximum allowed one sign per frontage.~~

**Part C:** A variance for four off-premises freestanding advertising signs on one sign structure with a setback of ~~64~~ 72.5 feet from the street centerline of IL Route 47 and a front yard of ~~23~~ 31.5 feet, in lieu of the minimum required setback of 85 feet and front yard of 35 feet along a State highway.

***{ SUBJECT TO THE FOLLOWING SPECIAL CONDITIONS: }***

The foregoing is an accurate and complete record of the Findings and Determination of the Zoning Board of Appeals of Champaign County.

SIGNED:

ATTEST:

Ryan Elwell, Chair  
Champaign County Zoning Board of Appeals

Secretary to the Zoning Board of Appeals

Date