



**CHAMPAIGN COUNTY BOARD
FACILITIES COMMITTEE AGENDA
County of Champaign, Urbana, Illinois**

Tuesday, May 7, 2024, at 6:30p.m.
Shields-Carter Meeting Room
Brookens Administrative Center
1776 E. Washington St., Urbana, IL 61802

Committee Members:

Jenny Lokshin – Chair	Carolyn Greer
Jeff Wilson – Vice Chair	Jennifer Locke
Stephanie Fortado	Mike Smith
Elly Hanauer-Friedman	Bethany Vanichtheeranont

<u>Agenda</u>	<u>Page #</u>
I. Call to Order and Roll Call	
II. Approval of Agenda/Addenda	
III. Approval of Minutes – April 2, 2024	1 - 4
IV. Public Participation	
V. Communications	
VI. New Business	
A. Update on ITB #2022-008 County Plaza Renovation Project – Bailey Edward Design – Karla Smalley, and Broeren Russo – Austin Barton (Photos Attached)	5 - 19
B. Discussion and Approval of Change Orders for ITB#2022-008 County Plaza Renovation Project (Change Orders #42, #43, #44 and composite of all change orders and pay applications to date Attached)	20 - 24
C. Discussion of Broeren Russo Minority Employment Report for March 2024 (Attached).	25
D. Update on ITB #2023-005 County Plaza Elevator Renovation Project – Bailey Edward Design – Karla Smalley	
E. Update on Courthouse Parking Lot Access Control Project – Bailey Edward Design – Karla Smalley	
F. Update on ITB#2022-009 Satellite Jail Consolidation (Photos Attached)	26 - 40
G. Discussion and Approval of Change Orders for ITB#2022-009 Satellite Jail Consolidation Project (Change Orders #39, #40, #41, #42, #43 and composite of all change orders and pay applications to date Attached)	41 - 47
H. Discussion of PJ Hoerr Minority Employment Reports for March of 2024 (To be distributed)	
I. Discussion and Award of Contract for County Highway Department Section #23-00469-00-RS METCAD Parking Lot Renovation Project (Bid Tab Summary Attached)	48 - 104
VII. Other Business	

All meetings are at the Brookens Administrative Center – 1776 E Washington Street in Urbana – unless otherwise noted. To enter Brookens after 4:30 p.m., enter at the north (rear) entrance located off Lierman Avenue. Champaign County will generally, upon request, provide appropriate aids and services leading to effective communication for qualified persons with disabilities. Please contact Administrative Services, 217-384-3776, as soon as possible but no later than 48 hours before the scheduled meeting.

- VIII. Presiding Officer's Report
 - A. Future Meeting – **June 4, 2024 @ 6:30pm**
- IX. Designation of Items to be Placed on the Consent Agenda
- X. Adjournment

All meetings are at the Brookens Administrative Center – 1776 E Washington Street in Urbana – unless otherwise noted. To enter Brookens after 4:30 p.m., enter at the north (rear) entrance located off Lierman Avenue. Champaign County will generally, upon request, provide appropriate aids and services leading to effective communication for qualified persons with disabilities. Please contact Administrative Services, 217-384-3776, as soon as possible but no later than 48 hours before the scheduled meeting.



**CHAMPAIGN COUNTY BOARD
FACILITIES COMMITTEE AGENDA
County of Champaign, Urbana, Illinois**

8 **MINUTES – Pending Approval**

9 **DATE:** Tuesday, April 2, 2024
10 **TIME:** 6:30 p.m.
11 **PLACE:** Shields-Carter Meeting Room
12 Brookens Administrative Center
13 1776 E. Washington St., Urbana IL 61802

14 **Committee Members**

15 **Present:** Stephanie Fortado, Elly Hanauer-Freidman, Jennifer Locke, Jenny Lokshin,
16 Bethany Vanichtheeranont, and Jeff Wilson
17

18 **Absent:** Carolyn Greer, Mike Smith
19

20 **County Staff:** Dana Brenner (Facilities Director), Chris Smith (Building and Grounds Manager),
21 Steve Summers (County Executive) and Mary Ward (Recording Clerk)
22

23 **Others Present:** Austin Barton (Broeren Russo) and Chris Bieser (Reifsteck Reid Architecture)

24 **Agenda**

25 **I. Call to Order and Roll Call**
26

27 Committee Chair Lokshin called the meeting to order at 6:30 p.m. Roll call was taken, and a
28 quorum was declared present.
29

30 **II. Approval of Agenda/Addenda**
31

32 **MOTION** by Ms. Locke to approve the agenda; seconded by Ms. Hanauer-Friedman. Upon
33 voice vote, the **MOTION CARRIED** unanimously.
34

35 **III. Approval of Minutes – March 5, 2024**
36

37 **MOTION** by Ms. Vanichtheeranont to approve the March 5, 2024 minutes; seconded by Ms.
38 Locke. Upon voice vote the **MOTION CARRIED** unanimously.
39

40 **IV. Public Participation**
41

42 **None**
43

44 **V. Communications**

45 Mr. Wilson thanked Mr. Brenner for organizing the tour of the Highway building. Ms. Lokshin
46 reminded the committee of the distribution of eclipse glasses at 9 a.m. on Friday, April 5. She
47 also thanked Mr. Brenner and Mr. Blue for the tour and told members they can also schedule
48 tours/meetings with department heads on their own.

49 **VI. New Business**

50
51
52
53
54
55
56
57
58
59
60
61
62
63
64
65
66
67
68
69
70
71
72
73
74
75
76
77
78
79
80
81
82
83
84
85
86
87
88
89
90
91
92
93
94
95
96

- A. Update on ITB #2022-008 County Plaza Renovation Project – Broeren Russo – Austin Barton

Ms. Smalley was unable to attend the meeting. Mr. Barton presented pictures and updates of the County Plaza Renovation Project. Ninety-nine percent of the ceilings are complete. The mechanicals are ready for start-up. The curtain wall is progressing and wrapping up. The counter tops are coming on Friday. All doors are hung on the third and fourth floors and all carpet is installed on the second, third and fourth floors. Work is progressing with the parking lot coating.

Ms. Hanauer-Friedman asked, excluding the elevators, when the project would be complete. It should be completed June 14. Mr. Wilson asked about testing when the mechanicals are started. That will be done by either the manufacturer or by a third party. Mr. Wilson asked whether there would be a ribbon cutting ceremony and about changing the name on the building. The Board has officially changed the name. The County Executive has drawings for putting the name on the building and there is the four-sided sign that also needs to be worked out. As to a ceremony, that date is undecided at this point, as we can't have the public in the building without elevators. Mr. Brenner also added that the tele-comm companies who had fiber in the building have removed it, except for one, who we don't know who it belongs to.

- B. Discussion and Approval of Change Orders for ITB#2022-008 County Plaza Renovation Project (Change Orders #33, #34, #35, #36, #37, #38, #39, #40 and #41 and composite of all change orders and pay applications to date)

Mr. Barton went over the change orders for the project. Change order 33 is to provide material for new blinds at the exterior windows. Change order 34 is for materials, labor, and equipment for 16 exterior lights. Change order 35 is to remove and replace ceramic tiles in three North lobbies and two South lobbies with LVT flooring. Change order 36 is to install two new dampers in Server Room 050.

Change order 37 is to remove and replace 4 drain bodies in the upper parking deck. Change order 38 to provide a new UPS and Bypass switch for server room. Change order 39 to install new door access hardware and cover plates per changes. Change order 40 to replace the S1 and S2 sinks specified and Change order 41 is to provide and install three quad power outlets in Room 112 for IT.

MOTION by Ms. Locke to recommend County Board approval of a resolution approving Change Orders 33, 34, 35, 36, 37, 38, 39, 40, and 41 for the County Plaza Renovation Project; seconded by Mr. Wilson. Upon voice vote, the **MOTION CARRIED** unanimously.

- C. Discussion of Broeren Russo Minority Employment Reports for January and February of 2024

97
98
99
100
101
102
103
104
105
106
107
108
109
110
111
112
113
114
115
116
117
118
119
120
121
122
123
124
125
126
127
128
129
130
131
132
133
134
135
136
137
138
139
140
141
142
143
144

The Minority Employment Reports for January and February were presented and discussed. Ms. Fortado asked how the percents were figured. It is based on hours worked. The employee numbers are based on contracts.

D. Update on ITB #2023-005 County Plaza Elevator Renovation Project

Mr. Brenner reported on their meeting with OTIS. We are waiting on an actual delivery date from them. We are told it will be the last week of May but were not given an actual date. We keep impressing on them how important this project is and the need to compress the timeline as much as possible.

E. Update on Courthouse Parking Lot Access Control Project

Mr. Brenner gave the update on the Parking Lot Access Control Project. It has finally started. We have enlarged the footprint of the project somewhat to allow more room as cars turn in. The concrete pedestal the equipment will be on was poured on Friday. All equipment is here and electrical has been run. Hopefully, we'll be able to set the equipment next week. Hopefully we'll be able to test the equipment in the 2-3 weeks and program key cards.

Ms. Lokshin asked about a sign she had seen about parking being enforced until 6 p.m. That will need to be checked out. The handicapped spaces and motorcycle spots will be available for the public.

F. Update on ITB#2022-009 Satellite Jail Consolidation – Reifsteck Reid Architecture – Chris Bieser

Mr. Bieser shared photos and gave an update on the Satellite Jail Consolidation Project. Windows are starting to go in and brickwork is progressing. Flooring is starting to go in. Pictures were shown of the mechanical chases. Maintenance will be able to easily access plumbing and some electrical from this access. It will be a huge time-saver for both maintenance and security staff at the jail.

G. Discussion and Approval of Change Orders for ITB#2022-009 Satellite Jail Consolidation Project (Change Orders #31, #32, #33, #34, #35, #36, #37, and #38 and composite of all change orders and pay applications to date)

Mr. Bieser explained the proposed change orders for the Satellite Jail Consolidation Project. Change order 31 is to add heat trace to the geothermal piping. Change order 32 adds hail guards to the rooftop units. Change order 33 is a credit for eliminating conduit for low voltage wiring. Change order 34 is a credit for eliminating swinging shower doors and to add mop holders to Janitor spaces.

Change order 35 provides additional water lines to the showers. Change order 36 is for additional pour stops for cantilevered deck areas. Change order 37 is to provide additional tube steel deck supports between joists. Changer order 38 is to provide and install additional ceiling access panels.

145
146
147
148
149
150
151
152
153
154
155
156
157
158
159
160
161
162
163
164
165
166
167
168
169
170
171
172
173
174
175
176
177
178
179
180
181
182
183
184
185
186
187

MOTION by Ms. Hanauer-Friedman to recommend County Board approval of a resolution approving Change Orders 31, 32, 33, 34, 35, 36, 37, and 38 for the Satellite Jail Consolidation Project; seconded by Ms. Locke. Upon voice vote, the **MOTION CARRIED** unanimously.

H. Discussion of PJ Hoerr Minority Employment Report for February of 2024

The PJ Hoerr Minority Employment Report for February was presented and discussed.

I. Update on Programming Study of Public Defender Space at the Courthouse

Mr. Brenner stated they have met with all parties and will be preparing notes for the department heads to proof to be sure nothing is left out. A final report will then be prepared. Everyone had great ideas. The goal is to put together a smart plan. At this point, it looks like there will be no funds available for this project until 2026.

Ms. Hanauer-Friedman asked about the need for a new court room. A rough estimate to establish a new court room is in the \$800,000 range. They are currently sharing court room. They are not happy with sharing but are making it work. Ms. Fortado asked how this project fits into the 10-year plan and possibly moving other items around. Mr. Brenner said it depends on the scope of the project. It may soon be time to re-visit the 10-year plan. Mr. Summers added that if expansion needs are more significant, we may have to look at an expansion to the East and that would be in the \$20 to \$25 million range.

VII. Other Business

There was no other business.

VIII. Presiding Officer’s Report

A. Future Meeting – **May 7, 2024 @ 6:30pm**

IX. Designation of Items to be Placed on the Consent Agenda

Items to be placed on the Consent Agenda include 6. B and G.

X. Adjournment

Chair Lokshin adjourned the meeting at 7:31 p.m.



Broeren Russo Builders, Inc.

Printed on Fri May 3, 2024 at 10:22 am CDT

Job #: 202269 Champaign County Plaza Renovation
102 E Main Street
Urbana, Illinois 61801

Unclassified

Description

Exterior Curtainwall is complete outside of two bays. Trim out covers remain.

Taken Date

05/03/2024 at 10:14 am

Upload Date

05/03/2024 at 10:16 am

Uploaded By

Austin Barton

File Name

[53E58DCF-62E9-4223-A...](#)





Broeren Russo Builders, Inc.

Printed on Fri May 3, 2024 at 10:22 am CDT

Job #: 202269 Champaign County Plaza Renovation
102 E Main Street
Urbana, Illinois 61801

Unclassified

Description

1st floor lobby tile work is underway.

Taken Date

05/03/2024 at 10:12 am

Upload Date

05/03/2024 at 10:16 am

Uploaded By

Austin Barton

File Name

[BC247226-2737-4147-A...](#)



Unclassified

Description
Building Sprinkler System
being pressure tested and
filled.

Taken Date
05/03/2024 at 10:11 am

Upload Date
05/03/2024 at 10:16 am

Uploaded By
Austin Barton

File Name
[998FCF9B-2316-4749-8...](#)



Unclassified

Description
New Electrical Gear
installed. Building is now
on permanent power.

Taken Date
05/03/2024 at 10:11 am

Upload Date
05/03/2024 at 10:16 am

Uploaded By
Austin Barton

File Name
[B8C099B9-6492-4713-A...](#)





Broeren Russo Builders, Inc.

Printed on Fri May 3, 2024 at 10:22 am CDT

Job #: 202269 Champaign County Plaza Renovation
102 E Main Street
Urbana, Illinois 61801

Unclassified

Description

Lower level security storage rooms are final painted.

Taken Date

05/03/2024 at 10:06 am

Upload Date

05/03/2024 at 10:16 am

Uploaded By

Austin Barton

File Name

[A4F2C451-7289-4533-A...](#)





Broeren Russo Builders, Inc.

Printed on Fri May 3, 2024 at 10:22 am CDT

Job #: 202269 Champaign County Plaza Renovation
102 E Main Street
Urbana, Illinois 61801

Unclassified

Description

Lower level curtainwall is installed.

Taken Date

05/03/2024 at 10:05 am

Upload Date

05/03/2024 at 10:16 am

Uploaded By

Austin Barton

File Name

[AB370771-E2B0-4EFA-9...](#)





Broeren Russo Builders, Inc.

Printed on Fri May 3, 2024 at 10:22 am CDT

Job #: 202269 Champaign County Plaza Renovation
102 E Main Street
Urbana, Illinois 61801

Unclassified

Description

New Generator Pad is poured. CTE cabinets also installed.

Taken Date

05/03/2024 at 10:03 am

Upload Date

05/03/2024 at 10:16 am

Uploaded By

Austin Barton

File Name

[515D7C8B-15C7-41F1-B...](#)





Broeren Russo Builders, Inc.

Printed on Fri May 3, 2024 at 10:22 am CDT

Job #: 202269 Champaign County Plaza Renovation
102 E Main Street
Urbana, Illinois 61801

Unclassified

Description
5th floor rooms ready for
final above ceiling
inspection.

Taken Date
05/03/2024 at 10:02 am

Upload Date
05/03/2024 at 10:16 am

Uploaded By
Austin Barton

File Name
[723F6413-9EDB-4E6F-A...](#)





Broeren Russo Builders, Inc.

Printed on Fri May 3, 2024 at 10:22 am CDT

Job #: 202269 Champaign County Plaza Renovation
102 E Main Street
Urbana, Illinois 61801

Unclassified

Description
5th floor ceilings
complete. Awaiting
inspection.

Taken Date
05/03/2024 at 10:00 am

Upload Date
05/03/2024 at 10:16 am

Uploaded By
Austin Barton

File Name
[57CAEDF7-F545-4DB9-A...](#)



Unclassified

Description
4th floor door security
installed.

Taken Date
05/03/2024 at 09:59 am

Upload Date
05/03/2024 at 10:16 am

Uploaded By
Austin Barton

File Name
[B1BD800F-ED8A-498F-9...](#)



Unclassified

Description
IT data racks getting
trimmed out.

Taken Date
05/03/2024 at 09:59 am

Upload Date
05/03/2024 at 10:16 am

Uploaded By
Austin Barton

File Name
[BC022C3B-E0C1-4DA0-9...](#)





Broeren Russo Builders, Inc.

Printed on Fri May 3, 2024 at 10:22 am CDT

Job #: 202269 Champaign County Plaza Renovation
102 E Main Street
Urbana, Illinois 61801

Unclassified

Description
North lobby VCT
installation per recent PR
approval.

Taken Date
05/03/2024 at 09:58 am

Upload Date
05/03/2024 at 10:16 am

Uploaded By
Austin Barton

File Name
[318E6364-AB5F-4E79-A...](#)





Broeren Russo Builders, Inc.

Printed on Fri May 3, 2024 at 10:22 am CDT

Job #: 202269 Champaign County Plaza Renovation
102 E Main Street
Urbana, Illinois 61801

Unclassified

Description

3rd floor GIS casework.
Plumbing trim out remains

Taken Date

05/03/2024 at 09:58 am

Upload Date

05/03/2024 at 10:16 am

Uploaded By

Austin Barton

File Name

[0037ED13-BDD4-4D37-...](#)



Unclassified

Description

All lobby millwork has been installed.
Countertops arriving next week.

Taken Date

05/03/2024 at 09:56 am

Upload Date

05/03/2024 at 10:16 am

Uploaded By

Austin Barton

File Name

[973D7365-ACA9-476B-A...](#)



Unclassified

Description
Millwork installation
complete.

Taken Date
05/03/2024 at 09:56 am

Upload Date
05/03/2024 at 10:16 am

Uploaded By
Austin Barton

File Name
[C68DEF10-3F8B-46CC-8...](#)





AIA® Document G701® – 2017

Change Order

PROJECT: *(Name and address)*
Champaign County Plaza Renovation
102 E. Main Street, Urbana IL 61801

CONTRACT INFORMATION:
Contract For: General Construction
Date: December 23, 2022

CHANGE ORDER INFORMATION:
Change Order Number: 042
Date: 04/22/2024

OWNER: *(Name and address)*
Champaign County Board
1776 E. Washington Street, Champaign,
IL 61622

ARCHITECT: *(Name and address)*
Bailey Edward Design Inc.
1103 S. Mattis Ave, Champaign IL 61821

CONTRACTOR: *(Name and address)*
Broeren Russo
602 N. County Fair Drive, Suite A,
Champaign, IL 61821

THE CONTRACT IS CHANGED AS FOLLOWS:

(Insert a detailed description of the change and, if applicable, attach or reference specific exhibits. Also include agreed upon adjustments attributable to executed Construction Change Directives.)

Provide all materials, labor, and equipment to provide ventilation at lower garage level. This work includes removing electrical conduits from existing condensing unit and power as required. As well as demo and installation associated with the louvers and CO monitoring.

The original Contract Sum was	\$	18,825,000.00
The net change by previously authorized Change Orders	\$	1,432,769.46
The Contract Sum prior to this Change Order was	\$	20,257,769.46
The Contract Sum will be increased by this Change Order in the amount of	\$	16,827.00
The new Contract Sum including this Change Order will be	\$	20,274,596.46

The Contract Time will be unchanged by (0) days.
The new date of Substantial Completion will be June 14, 2024

NOTE: This Change Order does not include adjustments to the Contract Sum or Guaranteed Maximum Price, or the Contract Time, that have been authorized by Construction Change Directive until the cost and time have been agreed upon by both the Owner and Contractor, in which case a Change Order is executed to supersede the Construction Change Directive.

NOT VALID UNTIL SIGNED BY THE ARCHITECT, CONTRACTOR AND OWNER.

Bailey Edward Design Inc.
ARCHITECT *(Firm name)*

SIGNATURE

Karla Smalley, Architect
PRINTED NAME AND TITLE

05.02.24
DATE

Broeren Russo
CONTRACTOR *(Firm name)*

SIGNATURE

Austin Barton, Project Manager
PRINTED NAME AND TITLE

05.02.2024
DATE

Champaign County Board
OWNER *(Firm name)*

SIGNATURE

Steve Summers, County Executive
PRINTED NAME AND TITLE

DATE

AIA[®] Document G701[®] – 2017

Change Order

PROJECT: <i>(Name and address)</i> Champaign County Plaza Renovation 102 E. Main Street, Urbana IL 61801	CONTRACT INFORMATION: Contract For: General Construction Date: December 23, 2022	CHANGE ORDER INFORMATION: Change Order Number: 043 Date: 04/22/2024
OWNER: <i>(Name and address)</i> Champaign County Board 1776 E. Washington Street, Champaign, IL 61622	ARCHITECT: <i>(Name and address)</i> Bailey Edward Design Inc. 1103 S. Mattis Ave, Champaign IL 61821	CONTRACTOR: <i>(Name and address)</i> Broeren Russo 602 N. County Fair Drive, Suite A, Champaign, IL 61821

THE CONTRACT IS CHANGED AS FOLLOWS:

(Insert a detailed description of the change and, if applicable, attach or reference specific exhibits. Also include agreed upon adjustments attributable to executed Construction Change Directives.)

Provide all materials, labor, and equipment to install two additional recepticals in the fourth floor interview rooms for video monitoring screens. Locations on attached floor plans.

The original Contract Sum was	\$ 18,825,000.00
The net change by previously authorized Change Orders	\$ 1,449,596.46
The Contract Sum prior to this Change Order was	\$ 20,274,596.46
The Contract Sum will be increased by this Change Order in the amount of	\$ 455.00
The new Contract Sum including this Change Order will be	\$ 20,275,051.46

The Contract Time will be unchanged by (0) days.
The new date of Substantial Completion will be June 14, 2024

NOTE: This Change Order does not include adjustments to the Contract Sum or Guaranteed Maximum Price, or the Contract Time, that have been authorized by Construction Change Directive until the cost and time have been agreed upon by both the Owner and Contractor, in which case a Change Order is executed to supersede the Construction Change Directive.

NOT VALID UNTIL SIGNED BY THE ARCHITECT, CONTRACTOR AND OWNER.

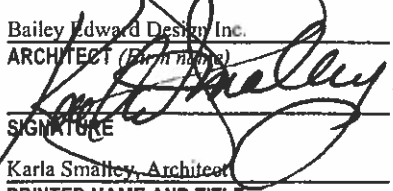
Bailey Edward Design Inc. ARCHITECT <i>(Firm name)</i>	Broeren Russo CONTRACTOR <i>(Firm name)</i>	Champaign County Board OWNER <i>(Firm name)</i>
 SIGNATURE	 SIGNATURE	 SIGNATURE
Karla Smalley, Architect PRINTED NAME AND TITLE	Austin Barton, Project Manager PRINTED NAME AND TITLE	Steve Summers, County Executive PRINTED NAME AND TITLE
05.02.24 DATE	05.02.2024 DATE	 DATE

AIA Document G701 – 2017. Copyright © 1979, 1987, 2000, 2001 and 2017. All rights reserved. "The American Institute of Architects," "American Institute of Architects," "AIA," the AIA Logo, and "AIA Contract Documents" are trademarks of The American Institute of Architects. This document was produced at 12:33:20 CT on 05/02/2024 under Order No.4104251657 which expires on 03/31/2025, is not for resale, is licensed for one-time use only, and may only be used in accordance with the AIA Contract Documents[®] Terms of Service. To report copyright violations, e-mail docinfo@aiacontracts.com.
User Notes: (3B9ADA3C)



AIA® Document G701® – 2017

Change Order

PROJECT: (Name and address)
Champaign County Plaza Renovation
102 E. Main Street, Urbana IL 61801

CONTRACT INFORMATION:
Contract For: General Construction
Date: December 23, 2022

CHANGE ORDER INFORMATION:
Change Order Number: 044
Date: 04/30/2024

OWNER: (Name and address)
Champaign County Board
1776 E. Washington Street, Champaign,
IL 61622

ARCHITECT: (Name and address)
Bailey Edward Design Inc.
1103 S. Mattis Ave, Champaign IL 61821

CONTRACTOR: (Name and address)
Broeren Russo
602 N. County Fair Drive, Suite A,
Champaign, IL 61821

THE CONTRACT IS CHANGED AS FOLLOWS:

(Insert a detailed description of the change and, if applicable, attach or reference specific exhibits. Also include agreed upon adjustments attributable to executed Construction Change Directives.)

Provide all materials, labor, and equipment to provide electrical power circuiting for the split coiling units located on the roof that service the north and south penthouse elevator equipment rooms.

The original Contract Sum was	\$	<u>18,825,000.00</u>
The net change by previously authorized Change Orders	\$	<u>1,450,051.46</u>
The Contract Sum prior to this Change Order was	\$	<u>20,275,051.46</u>
The Contract Sum will be increased by this Change Order in the amount of	\$	<u>4,886.00</u>
The new Contract Sum including this Change Order will be	\$	<u>20,279,937.46</u>

The Contract Time will be unchanged by (0) days.
The new date of Substantial Completion will be June 14, 2024

NOTE: This Change Order does not include adjustments to the Contract Sum or Guaranteed Maximum Price, or the Contract Time, that have been authorized by Construction Change Directive until the cost and time have been agreed upon by both the Owner and Contractor, in which case a Change Order is executed to supersede the Construction Change Directive.

NOT VALID UNTIL SIGNED BY THE ARCHITECT, CONTRACTOR AND OWNER.

Bailey Edward Design Inc.
ARCHITECT (Firm name)

Broeren Russo
CONTRACTOR (Firm name)

Champaign County Board
OWNER (Firm name)

SIGNATURE

SIGNATURE

SIGNATURE

Karla Smalley, Architect
PRINTED NAME AND TITLE

Austin Barton, Project Manager
PRINTED NAME AND TITLE

Steve Summers, County Executive
PRINTED NAME AND TITLE

05.02.24
DATE

05.02.2024
DATE

DATE

AIA Document G701 – 2017. Copyright © 1979, 1987, 2000, 2001 and 2017. All rights reserved. "The American Institute of Architects," "American Institute of Architects," "AIA," the AIA Logo, and "AIA Contract Documents" are trademarks of The American Institute of Architects. This document was produced at 12:38:57 CT on 05/02/2024 under Order No.4104251657 which expires on 03/31/2025, is not for resale, is licensed for one-time use only, and may only be used in accordance with the AIA Contract Documents® Terms of Service. To report copyright violations, e-mail docinfo@aiacontracts.com.

County Plaza Renovation Project

Broeren Russo Change Orders and Total Expenses

#	Broeren Russo Contract Amount	<u>Date</u>	<u>Change Order Amount</u>		<u>Updated Contract Amount</u>	<u>Change Orders on Pay Applications</u>	<u>Posted Change Orders</u>
					\$ 18,825,000.00		
#1	<u>Changing metal stud gauge from 18 to 20 credit</u>	02.10.2023	\$ (85,000.00)	Pay App #1	\$ 18,740,000.00	Pay App #1	\$ (85,000.00)
#2	<u>Combined a change in 5 elements credit</u>	03.01.2023	\$ (90,603.00)	Pay App #3	\$ 18,649,397.00	Pay App #3	\$ (175,629.00)
#3	Sofit demolition	04.07.2023	\$ 53,618.00	Pay App #4	\$ 18,703,015.00	Pay App #4	
#4	Membrane roof change	04.27.2023	\$ 11,967.00	Pay App #4	\$ 18,714,982.00	Pay App #4	
#5	Combined 4 different changes	05.09.2023	\$ 219,502.98	Pay App #4	\$ 18,934,484.98	Pay App #4	
#6	Standpipe alteration	05.16.2023	\$ 25,338.58	Pay App #4	\$ 18,959,823.56	Pay App #4	
#7	Culvert change	05.17.2023	\$ 28,163.85	Pay App #4	\$ 18,987,987.41	Pay App #4	
#8	<u>Changed to all new doors</u>	05.18.2023	\$ 24,994.92	Pay App #4	\$ 19,012,982.33	Pay App #4	\$ 187,982.33
#9	Sanitary line repair	05.30.2023	\$ 94,397.29	Pay App #5	\$ 19,107,379.62	Pay App #5	
#10	Roof deck structural steel	05.31.2023	\$ 458,239.25	Pay App #5	\$ 19,565,618.87	Pay App #5	
#11	Curtain wall change	06.01.2023	\$ 101,545.40	Pay App #5	\$ 19,667,164.27	Pay App #5	
#12	<u>Water meter valves</u>	06.21.2023	\$ 3,192.51	Pay App #5	\$ 19,670,356.78	Pay App #5	\$ 845,356.78
#13	Conduit for exterior lighting	07.25.2023	\$ 3,000.00	Pay App #7	\$ 19,673,356.78	Pay App #7	
#14	Four corners asbestos removal	07.26.2023	\$ 56,105.50	Pay App #7	\$ 19,729,462.28	Pay App #7	
#15	Room modifications	07.31.2023	\$ 42,091.35	Pay App #7	\$ 19,771,553.63	Pay App #7	
#16	<u>Ceiling tile selection credit</u>	08.03.2023	\$ (16,000.00)	Pay App #7	\$ 19,755,553.63	Pay App #7	\$ 930,553.63
#17	Fencing modifications and removal	09.19.2023	\$ (39,000.00)		\$ 19,716,553.63		
#18	<u>Ballistic panel credit for not being installed above ceiling</u>	09.27.2023	\$ (2,000.00)	Pay App #9	\$ 19,714,553.63	Pay App #9	\$ 893,453.63
#19	5th floor modifications for Public Defender	09.27.2023	\$ 63,526.39	Pay App #10	\$ 19,778,080.02	Pay App #10	
#20	Credit change in level 5 wall mud/sanding finish	09.27.2023	\$ (23,000.00)	Pay App #10	\$ 19,755,080.02	Pay App #10	
#21	<u>Modification to gas/water line by city inspector</u>	09.27.2023	\$ 6,318.88	Pay App #10	\$ 19,761,398.90	Pay App #10	\$ 897,398.90
#22	Over payment credit back to County	11.28.2023	\$ (26.00)	Pay App #11	\$ 19,761,372.90	Pay App #11	
#23	Installation of additionally ballistic panels on first level	11.29.2023	\$ 2,000.00	Pay App #11	\$ 19,763,372.90	Pay App #11	
#24	<u>New perimeter soffit to close the ceiling from the interior</u>	11.29.2023	\$ 190,718.00	Pay App #11	\$ 19,954,090.90	Pay App #11	\$ 1,168,090.90
#25	Installation of duress pushbuttons	01.31.2024	\$ 48,458.00	Pay App #13	\$ 20,002,548.90	Pay App #13	
#26	Installation of conduit on LL for future EV Charging Station	01.31.2024	\$ 13,438.00	Pay App #13	\$ 20,015,986.90	Pay App #13	
#27	Insatallation of south Chase flooring	02.01.2024	\$ 18,594.00	Pay App #13	\$ 20,034,580.90	Pay App #13	
#28	Installation of newhouse bib on roof	02.01.2024	\$ 1,971.00	Pay App #13	\$ 20,036,551.90	Pay App #13	
#29	Replacement of water lines where steel was placed	02.01.2024	\$ 16,095.00	Pay App #13	\$ 20,052,646.90	Pay App #13	
#30	<u>Install a new 3" drainpipe in south canopy</u>	02.28.2024	\$ 18,539.00	Pay App #13	\$ 20,071,185.90	Pay App #13	\$ 1,285,185.90
#31	Install a new pressure tank bladder	02.28.2024	\$ 4,934.00		\$ 20,076,119.90		
#32	Credit to project for not installing 15 TV's	02.29.2024	\$ (4,069.80)		\$ 20,072,050.10		
#33	Provide material for new blinds at exterior windows	03.26.2024	\$ 64,271.00		\$ 20,136,321.10		
#34	Provide materials, labor and equipment for exterior 16 lights	03.26.2024	\$ 29,753.00		\$ 20,166,074.10		
#35	Remove ceramic tile in 3 N lobbies 2 S lobbies and replace	03.26.2024	\$ 26,500.00		\$ 20,192,574.10		
#36	Insatall 2 new dampers in server room	03.26.2024	\$ 3,148.00		\$ 20,195,722.10		
#37	Remove and replace 4 drain bodies in upper parking deck	03.26.2024	\$ 7,150.36		\$ 20,202,872.46		
#38	Provide new UPS and Bypass switch for server room	03.26.2024	\$ 38,907.00		\$ 20,241,779.46		
#39	Install new door access hardware & cover plate per changes	03.26.2024	\$ 4,873.00		\$ 20,246,652.46		
#40	Replace the S1 & S2 sinks specified	03.26.2024	\$ 2,246.00		\$ 20,248,898.46		

		<u>Date</u>	<u>Change Order Amount</u>	<u>Updated Contract Amount</u>	<u>Change Orders on Pay Applications</u>	<u>Posted Change Orders</u>
#41	Install 3-quad power outlets in room 122.	03.27.2024	\$ 8,871.00	\$ 20,257,769.46		
#42	Install air lovers and CO monitoring equipment to lower garage	04.22.2024	\$ 16,827.00	\$ 20,274,596.46		
#43	Install two electric recepticals in fourth floor interview rooms	04.22.2024	\$ 455.00	\$ 20,275,051.46		
#44	Install electric power to both penthouse split coiling units	04.30.2024	\$ 4,886.00	\$ 20,279,937.46		
Total			\$ 1,454,937.46	\$ 20,248,898.47		

<u>Pay Applications</u>	<u>Date</u>	<u>Amount</u>	<u>Retainage</u>	<u>Remaining</u>
Pay App #1	03.21.2023	\$ 1,065,770.90	\$ 118,419.00	\$ 19,183,127.57
Pay App #2	05.02.2023	\$ 1,228,115.43	\$ 136,457.30	\$ 17,955,012.14
Pay App #3	05.31.2023	\$ 1,514,736.81	\$ 168,304.12	\$ 16,440,275.33
Pay App #4	06.27.2023	\$ 1,572,927.60	\$ 146,992.01	\$ 14,867,347.73
Pay App #5	07.06.2023	\$ 534,014.52	\$ 59,334.95	\$ 14,333,333.21
Pay App #6	08.03.2023	\$ 1,191,937.78	\$ 132,437.55	\$ 13,141,395.43
Pay App #7	09.11.2023	\$ 1,023,261.88	\$ 113,695.82	\$ 12,118,133.55
Pay App #8	10.04.2023	\$ 901,711.67	\$ 100,190.29	\$ 11,216,421.88
Pay App #9	11.01.2023	\$ 915,624.53	\$ 101,736.10	\$ 10,300,797.35
Pay App #10	12.04.2023	\$ 852,771.27	\$ 93,977.05	\$ 9,448,026.08
Pay App #11	01.02.2024	\$ 894,570.63	\$ 99,187.07	\$ 8,553,455.45
Pay App #12	02.02.2024	\$ 1,604,620.08	\$ 150,192.20	\$ 6,948,835.37
Pay App #13	03.05.2024	\$ 1,125,200.49	\$ 123,617.60	\$ 5,823,634.88
Pay App #14	04.10.2024	\$ 692,118.00	\$ 72,640.70	\$ 5,131,516.88
TOTAL		\$ 15,117,381.59	\$ 1,617,181.76	

Project Name: Champaign County Plaza
 Project #: 202269
 Project Manager: Austin Barton



Payroll - December	Date	Total # Workers	Females		Minorities		Veterans	
			Number	Percent	Number	Percent	Number	Percent
Cumulative Prior Months	02/01/2023 - 2/29/2024	514	12	3.7%	39	14.7%	12	1%
Current	3/1/2024	82	1	1%	6	13.01%	1	1%
GRAND TOTAL		596						

	African American	Hispanic	Native American	Asian	Caucasian	Veteran	Female	Total Employed
Associated	1	1			23		1	26
DHM Plumbing					3	1		4
DHM HVAC					6	1		7
Davis Electric	1				7			8
Western					7			7
BRCI		2			17			19

































AIA Document G701® – 2017

Change Order

PROJECT: *(Name and address)*
Champaign County Jail Consolidation

CONTRACT INFORMATION:
Contract For: General Construction
Date: January 6, 2023

CHANGE ORDER INFORMATION:
Change Order Number: 039
Date: April 5, 2024

OWNER: *(Name and address)*
Champaign County Board
Champaign County Physical Plant
1776 East Washington
Urbana IL 61802-4581

ARCHITECT: *(Name and address)*
Reifsteck Reid & Company Architects
909 Arrow Road, Champaign IL 61821

CONTRACTOR: *(Name and address)*
PJ Hoerr, Inc
107 N Commerce Place
Peoria, IL 61604

THE CONTRACT IS CHANGED AS FOLLOWS:

(Insert a detailed description of the change and, if applicable, attach or reference specific exhibits. Also include agreed upon adjustments attributable to executed Construction Change Directives.)

Per RFP 022, provide emergency power for temperature control switches and fire fighter smoke control station and relocate fire alarm addressable control modules.

The original Contract Sum was	\$ 22,228,357.00
The net change by previously authorized Change Orders	\$ 63,007.16
The Contract Sum prior to this Change Order was	\$ 22,291,364.16
The Contract Sum will be increased by this Change Order in the amount of	\$ 8,117.76
The new Contract Sum including this Change Order will be	\$ 22,299,481.92

The Contract Time will be unchanged by Zero (0) days.
The new date of Substantial Completion will be unchanged

NOTE: This Change Order does not include adjustments to the Contract Sum or Guaranteed Maximum Price, or the Contract Time, that have been authorized by Construction Change Directive until the cost and time have been agreed upon by both the Owner and Contractor, in which case a Change Order is executed to supersede the Construction Change Directive.

NOT VALID UNTIL SIGNED BY THE ARCHITECT, CONTRACTOR AND OWNER.

Reifsteck Reid & Company Architects
ARCHITECT *(Firm name)*

PJ Hoerr, Inc.
CONTRACTOR *(Firm name)*

Champaign County Board
OWNER *(Firm name)*

SIGNATURE

SIGNATURE

SIGNATURE

Chris Bieser, Project Manager
PRINTED NAME AND TITLE

Colin Logue, Vice President
PRINTED NAME AND TITLE

PRINTED NAME AND TITLE

April 5, 2024
DATE

April 10, 2024
DATE

DATE



AIA® Document G701® – 2017

Change Order

PROJECT: *(Name and address)*
Champaign County Jail Consolidation

CONTRACT INFORMATION:
Contract For: General Construction
Date: January 6, 2023

CHANGE ORDER INFORMATION:
Change Order Number: 040
Date: April 5, 2024

OWNER: *(Name and address)*
Champaign County Board
Champaign County Physical Plant
1776 East Washington
Urbana IL 61802-4581

ARCHITECT: *(Name and address)*
Reifsteck Reid & Company Architects
909 Arrow Road, Champaign IL 61821

CONTRACTOR: *(Name and address)*
PJ Hoerr, Inc
107 N Commerce Place
Peoria, IL 61604

THE CONTRACT IS CHANGED AS FOLLOWS:

(Insert a detailed description of the change and, if applicable, attach or reference specific exhibits. Also include agreed upon adjustments attributable to executed Construction Change Directives.)

Delete security mesh and modify ceiling elevation in Rooms 157 & 159

The original Contract Sum was	\$ 22,228,357.00
The net change by previously authorized Change Orders	\$ 71,124.92
The Contract Sum prior to this Change Order was	\$ 22,299,481.92
The Contract Sum will be decreased by this Change Order in the amount of	\$ 4,606.00
The new Contract Sum including this Change Order will be	\$ 22,294,875.92

The Contract Time will be unchanged by Zero (0) days.

The new date of Substantial Completion will be unchanged

NOTE: This Change Order does not include adjustments to the Contract Sum or Guaranteed Maximum Price, or the Contract Time, that have been authorized by Construction Change Directive until the cost and time have been agreed upon by both the Owner and Contractor, in which case a Change Order is executed to supersede the Construction Change Directive.

NOT VALID UNTIL SIGNED BY THE ARCHITECT, CONTRACTOR AND OWNER.

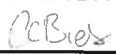
Reifsteck Reid & Company Architects
ARCHITECT *(Firm name)*

SIGNATURE

Chris Bieser, Project Manager
PRINTED NAME AND TITLE

April 5, 2024
DATE

PJ Hoerr, Inc
CONTRACTOR *(Firm name)*

SIGNATURE

Colin Logue, Vice President
PRINTED NAME AND TITLE

April 10, 2024
DATE

Champaign County Board
OWNER *(Firm name)*

SIGNATURE

PRINTED NAME AND TITLE

DATE



AIA® Document G701® – 2017

Change Order

PROJECT: (Name and address)
Champaign County Jail Consolidation

CONTRACT INFORMATION:
Contract For: General Construction
Date: January 6, 2023

CHANGE ORDER INFORMATION:
Change Order Number: 041
Date: April 17, 2024

OWNER: (Name and address)
Champaign County Board
Champaign County Physical Plant
1776 East Washington
Urbana IL 61802-4581

ARCHITECT: (Name and address)
Reifsteck Reid & Company Architects
909 Arrow Road, Champaign IL 61821

CONTRACTOR: (Name and address)
PJ Hoerr, Inc.
107 N Commerce Place
Peoria, IL 61604

THE CONTRACT IS CHANGED AS FOLLOWS:

(Insert a detailed description of the change and, if applicable, attach or reference specific exhibits. Also include agreed upon adjustments attributable to executed Construction Change Directives.)

Per RFP 016, remodel Booking area.

The original Contract Sum was	\$ 22,228,357.00
The net change by previously authorized Change Orders	\$ 66,518.92
The Contract Sum prior to this Change Order was	\$ 22,294,875.92
The Contract Sum will be increased by this Change Order in the amount of	\$ 83,733.17
The new Contract Sum including this Change Order will be	\$ 22,378,609.09

The Contract Time will be unchanged by Zero (0) days.
The new date of Substantial Completion will be unchanged

NOTE: This Change Order does not include adjustments to the Contract Sum or Guaranteed Maximum Price, or the Contract Time, that have been authorized by Construction Change Directive until the cost and time have been agreed upon by both the Owner and Contractor, in which case a Change Order is executed to supersede the Construction Change Directive.

NOT VALID UNTIL SIGNED BY THE ARCHITECT, CONTRACTOR AND OWNER.

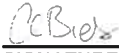
Reifsteck Reid & Company Architects
ARCHITECT (Firm name)

SIGNATURE

PJ Hoerr, Inc.
CONTRACTOR (Firm name)

SIGNATURE

Champaign County Board
OWNER (Firm name)

SIGNATURE

Chris Bieser, Project Manager
PRINTED NAME AND TITLE

Colin Logue, Vice President
PRINTED NAME AND TITLE

PRINTED NAME AND TITLE

April 17, 2024
DATE

April 17, 2024
DATE

DATE



AIA® Document G701® – 2017

Change Order

PROJECT: *(Name and address)*
Champaign County Jail Consolidation

CONTRACT INFORMATION:
Contract For: General Construction
Date: January 6, 2023

CHANGE ORDER INFORMATION:
Change Order Number: 042
Date: April 17, 2024

OWNER: *(Name and address)*
Champaign County Board
Champaign County Physical Plant
1776 East Washington
Urbana IL 61802-4581

ARCHITECT: *(Name and address)*
Reifsteck Reid & Company Architects
909 Arrow Road, Champaign IL 61821

CONTRACTOR: *(Name and address)*
PJ Hoerr, Inc.
107 N Commerce Place
Peoria, IL 61604

THE CONTRACT IS CHANGED AS FOLLOWS:

(Insert a detailed description of the change and, if applicable, attach or reference specific exhibits. Also include agreed upon adjustments attributable to executed Construction Change Directives.)

Security caulking at ceiling deck seams in cells

The original Contract Sum was	\$ 22,228,357.00
The net change by previously authorized Change Orders	\$ 150,252.09
The Contract Sum prior to this Change Order was	\$ 22,378,609.09
The Contract Sum will be increased by this Change Order in the amount of	\$ 14,333.55
The new Contract Sum including this Change Order will be	\$ 22,392,942.64

The Contract Time will be unchanged by Zero (0) days.
The new date of Substantial Completion will be unchanged

NOTE: This Change Order does not include adjustments to the Contract Sum or Guaranteed Maximum Price, or the Contract Time, that have been authorized by Construction Change Directive until the cost and time have been agreed upon by both the Owner and Contractor, in which case a Change Order is executed to supersede the Construction Change Directive.

NOT VALID UNTIL SIGNED BY THE ARCHITECT, CONTRACTOR AND OWNER.

Reifsteck Reid & Company Architects
ARCHITECT *(Firm name)*

SIGNATURE

PJ Hoerr, Inc.
CONTRACTOR *(Firm name)*

SIGNATURE

Champaign County Board
OWNER *(Firm name)*

SIGNATURE

Chris Bieser, Project Manager
PRINTED NAME AND TITLE

Colin Logue, Vice President
PRINTED NAME AND TITLE

PRINTED NAME AND TITLE

April 17, 2024
DATE

April 17, 2024
DATE

DATE



Change Order

PROJECT: *(Name and address)*
Champaign County Jail Consolidation

CONTRACT INFORMATION:
Contract For: General Construction
Date: January 6, 2023

CHANGE ORDER INFORMATION:
Change Order Number: 043
Date: April 30, 2024

OWNER: *(Name and address)*
Champaign County Board
Champaign County Physical Plant
1776 East Washington
Urbana IL 61802-4581

ARCHITECT: *(Name and address)*
Reifsteck Reid & Company Architects
909 Arrow Road, Champaign IL 61821

CONTRACTOR: *(Name and address)*
PJ Hoerr, Inc.
107 N Commerce Place
Peoria, IL 61604

THE CONTRACT IS CHANGED AS FOLLOWS:

(Insert a detailed description of the change and, if applicable, attach or reference specific exhibits. Also include agreed upon adjustments attributable to executed Construction Change Directives.)

Per RFP 023, provide glazing enclosing skylight shafts in Med Iso Cells 110 and 111

The original Contract Sum was	\$	<u>22,228,357.00</u>
The net change by previously authorized Change Orders	\$	<u>164,585.64</u>
The Contract Sum prior to this Change Order was	\$	<u>22,392,942.64</u>
The Contract Sum will be increased by this Change Order in the amount of	\$	<u>20,939.10</u>
The new Contract Sum including this Change Order will be	\$	<u>22,413,881.74</u>

The Contract Time will be unchanged by Zero (0) days.
The new date of Substantial Completion will be unchanged

NOTE: This Change Order does not include adjustments to the Contract Sum or Guaranteed Maximum Price, or the Contract Time, that have been authorized by Construction Change Directive until the cost and time have been agreed upon by both the Owner and Contractor, in which case a Change Order is executed to supersede the Construction Change Directive.

NOT VALID UNTIL SIGNED BY THE ARCHITECT, CONTRACTOR AND OWNER.

Reifsteck Reid & Company Architects
ARCHITECT *(Firm name)*

PJ Hoerr, Inc
CONTRACTOR *(Firm name)*

Champaign County Board
OWNER *(Firm name)*

SIGNATURE

SIGNATURE

SIGNATURE

Chris Bieser, Project Manager
PRINTED NAME AND TITLE

PRINTED NAME AND TITLE

PRINTED NAME AND TITLE

April 30, 2024
DATE

DATE

DATE

**Satellite Jail Consolidation Project
JP Hoerr Change Orders and Total Expenses**

#	JP Hoerr Contract Amount	Date	Change Order Amount	Updated Contract Amount	Pay Application #
				\$ 22,228,357.00	
#1	Credit to modifications of foundation types and reinforcement	04.05.2023	\$ (744.00)	\$ 22,227,613.00	Pay App #1
#2	Unsuitable soil in parking lot extension adding stone	04.27.2023	\$ 2,114.33	\$ 22,229,727.33	Pay App #2
#3	Upgrade two water coolers to security grade	04.28.2023	\$ 19,123.53	\$ 22,248,850.86	Pay App #2
#4	Directional boring of fiber under retention basin	05.04.2023	\$ 34,626.90	\$ 22,283,477.76	Pay App #3
#5	Hand digging to locate fiber optic conduits	07.10.2023	\$ 793.80	\$ 22,284,271.56	Pay App #5
#6	Provide floor mounted u-shape bollard to protect gas main	07.10.2023	\$ 2,472.75	\$ 22,286,744.31	Pay App #5
#7	Provide credit for deleting all retractable bollards	07.10.2023	\$ (268,445.00)	\$ 22,018,299.31	Pay App #5
#8	Remove face frames for plastic laminate casework and certification	07.21.2023	\$ (19,346.00)	\$ 21,998,953.31	Pay App #7
#9	Change in masonry grout and seating of baring plates	07.26.2023	\$ 5,145.00	\$ 22,004,098.31	Pay App #7
#10	Install new CMU wall over ductbank in lieu of removing concrete	09.22.2023	\$ (6,905.00)	\$ 21,997,193.31	Pay App #8
#11	Change return air temperature sensors	09.22.2023	\$ 6,013.04	\$ 22,003,206.35	Pay App #8
#12	Add additional fire dampers I duct penetrations of rated walls	09.22.2023	\$ 4,608.48	\$ 22,007,814.83	Pay App #8
#13	Remove portion of ductbank and thicken slab recreation space	10.27.2023	\$ 5,533.16	\$ 22,013,347.99	Pay App #9
#14	Credit for elimination of razer wire within refuge area	10.27.2023	\$ (19,320.00)	\$ 21,994,027.99	Pay App #9
#15	Add two overflow roof drains on existing roof	10.27.2023	\$ 24,579.67	\$ 22,018,607.66	Pay App #9
#16	Add concrete pavement to both outdoor recreation areas	11.01.2023	\$ 64,754.55	\$ 22,083,362.21	Pay App #9
#17	Expanded retention basin final price	11.01.2023	\$ 133,089.30	\$ 22,216,451.51	Pay App #9
#18	Additional piping required to connect underdrains due to elevation ct	11.01.2023	\$ 12,175.29	\$ 22,228,626.80	Pay App #9
#19	Provide additional rebar for exterior security walls	11.02.2023	\$ 8,820.00	\$ 22,237,446.80	Pay App #9
#20	Add Fastening of angle to existing precast	11.10.2023	\$ 338.40	\$ 22,237,785.20	Pay App #10
#21	Provide electric/fire alarm magnetic holds for door 156	11.14.2023	\$ 3,401.21	\$ 22,241,186.41	Pay App #10
#22	Provide new inmate property storage	11.16.2023	\$ 32,632.10	\$ 22,273,818.51	\$ 45,461.51 Pay App #10
#23	Repair gas leaks in existing building	01.10.2024	\$ 3,453.04	\$ 22,277,271.55	Pay App #13
#24	Wiring change from Ameren transf. to interior switchboard	01.10.2024	\$ 3,093.92	\$ 22,280,365.47	Pay App #13
#25	Provide & install two fire extinguishers and cabinets	01.22.2024	\$ 2,661.75	\$ 22,283,027.22	Pay App #13
#26	Epoxy paint modifications in detention cells	01.31.2024	\$ 7,098.51	\$ 22,290,125.73	Pay App #13
#27	Revise tectum ceiling framing & reduce security mesh	02.01.2024	\$ (39,848.00)	\$ 22,250,277.73	Pay App #13
#28	Modifications to lighting & controls I rec space	02.01.2024	\$ 10,168.77	\$ 22,260,446.50	Pay App #13
#29	Modifications to door hardware and security modifications	02.09.2024	\$ 6,524.08	\$ 22,266,970.58	Pay App #13
#30	Provide isolation valves and flush valves for Geothermal	02.09.2024	\$ 2,823.21	\$ 22,269,793.79	\$ 41,436.79 Pay App #13
#31	Install trace heat to above ground exterior geothermal piping	03.26.2024	\$ 10,354.62	\$ 22,280,148.41	
#32	Install hail guards to rooftop HVAC equipment	03.26.2024	\$ 10,673.91	\$ 22,290,822.32	
#33	Provide credit for eliminating low volatge wiring	03.26.2024	\$ (15,248.15)	\$ 22,275,574.17	
#34	Provide credit for eliminating swinging shower doors	03.26.2024	\$ (23,690.00)	\$ 22,251,884.17	
#35	Add water line to give both cold & tempered H2O to showers	03.27.2024	\$ 12,281.69	\$ 22,264,165.86	
#36	Install additional pour stops to cantilevered deck areas	03.27.2024	\$ 2,126.25	\$ 22,266,292.11	
#37	Provide additional tube steel deck supports between joists	03.27.2024	\$ 1,047.00	\$ 22,267,339.11	
#38	Provide and install additional ceiling access panels	03.27.2024	\$ 24,025.05	\$ 22,291,364.16	

#39	Provide emergency power for temperature control switches	04.05.2024	\$ 8,117.76	\$ 22,299,481.92
#40	Eliminate security mesh & modify ceilings in Rooms 157 & 159	04.05.2024	\$ (4,606.00)	\$ 22,294,875.92
#41	Remodel Booking area	04.17.2024	\$ 83,733.17	\$ 22,378,609.09
#42	Add security caulking at deiling decks seams in cells	04.17.2024	\$ 14,333.55	\$ 22,392,942.64
#43	Provide glazing enclosing skylight shafts in Med Iso 110 & 111	04.30.2024	\$ 20,939.10	\$ 22,413,881.74
	Total		\$ 63,007.16	\$ 22,269,793.79

Satellite Jail Consolidation Project

JP Hoerr Pay Applications

	<u>Date</u>	<u>Amount</u>	<u>Retainage</u>	<u>Remaining</u>
Pay App #1	03.08.2023	\$ 208,654.20	\$ 23,183.80	\$ 22,061,139.59
Pay App #2	05.09.2023	\$ 211,273.70	\$ 23,474.87	\$ 21,849,865.89
Pay App #3	06.06.2023	\$ 1,669,867.88	\$ 185,540.89	\$ 20,179,998.01
Pay App #4	07.06.2023	\$ 1,002,431.49	\$ 111,381.28	\$ 19,177,566.52
Pay App #5	08.03.2023	\$ 1,585,376.23	\$ 176,152.91	\$ 17,592,190.29
Pay App #6	09.01.2023	\$ 1,656,430.30	\$ 183,547.81	\$ 15,935,759.99
Pay App #7	09.29.2023	\$ 1,566,693.63	\$ 175,577.08	\$ 14,369,066.36
Pay App #8	11.01.2023	\$ 1,244,074.52	\$ 137,230.53	\$ 13,124,991.84
Pay App #9	11.28.2023	\$ 1,850,080.94	\$ 205,564.58	\$ 11,274,910.90
Pay App #10	01.10.2024	\$ 1,225,779.49	\$ 136,197.75	\$ 10,049,131.41
Pay App #11	02.06.2024	\$ 1,576,430.01	\$ 175,158.90	\$ 8,472,701.40
Pay App #12	03.05.2024	\$ 1,286,275.36	\$ 142,919.57	\$ 7,186,426.04
Pay App # 13	04.22.2024	\$ 1,399,407.18	\$ 155,489.73	\$ 5,787,018.86
	TOTAL	\$ 16,482,774.93	\$ 1,831,419.70	



Tabulation of Bids



Local Public Agency Champaign County Highway Department	County Champaign	Section Number 23-00469-00-RS	Letting Date 04/30/24
---	----------------------------	---	---------------------------------

Approved Engineer's Estimate \$223,660.50	Attended By (IDOT Representative(s)) <div style="border: 1px solid black; height: 80px; width: 100%;"></div>
---	---

Bidder's Name	Cross Construction, Inc	Open Road Paving, LLC	
Bidder's Address	3615 N Countryview Rd	1414 W Anthony Dr	
City, State, Zip	Urbana, IL 61802	Urbana, IL 61802	
Proposal Guarantee	Bid Bond-5%	Bid Bond-5%	
Terms			

Approved Engineer's Estimate

Item No.	Item	Delivery	Unit	Quantity	Unit Price	Total	Unit Price	Total	Unit Price	Total	Unit Price	Total
40600275	BIT MAT, PRIME COAT		POUND	0	\$2.0000	\$0.00	\$0.8000	\$0.00	\$1.1500	\$0.00		\$0.00
40600290	BIT MAT, TACK COAT		POUND	1951	\$2.5000	\$4,877.50	\$1.0000	\$1,951.00	\$2.5000	\$4,877.50		\$0.00
40603240	POLY HMA BIND. IL 19, N90		TON	0	\$215.0000	\$0.00	\$170.0000	\$0.00	\$199.6000	\$0.00		\$0.00
40604152	PLY HMA SURF CSE IL9.5 I		TON	486	\$235.0000	\$114,210.00	\$175.0000	\$85,050.00	\$207.1500	\$100,674.90		\$0.00
42400800	DETECTABLE WARNINGS		SQ FT	18	\$20.0000	\$360.00	\$95.0000	\$1,710.00	\$89.5000	\$1,611.00		\$0.00
44000157	HMA SURF REM 2"		SQ YD	4336	\$10.0000	\$43,360.00	\$10.0000	\$43,360.00	\$5.5000	\$23,848.00		\$0.00
44201723	CLS D PTCH, TYPE IV, 6"		SQ YD	128	\$400.0000	\$51,200.00	\$160.0000	\$20,480.00	\$332.0000	\$42,496.00		\$0.00
67100100	MOBILIZATION		L SUM	.5	\$15,000.0000	\$7,500.00	\$9,500.0000	\$4,750.00	\$21,600.0000	\$10,800.00		\$0.00
78001100	PAINT PVT MARK L&S		SQ FT	13	\$20.0000	\$260.00	\$16.5000	\$214.50	\$10.0000	\$130.00		\$0.00
78001110	PAINT PVT MARK LINE, 4"		FOOT	1965	\$0.2000	\$393.00	\$1.0500	\$2,063.25	\$3.0000	\$5,895.00		\$0.00
X7010216	TRAFFIC CONTR & PROT.		L SUM	.5	\$3,000.0000	\$1,500.00	\$5,000.0000	\$2,500.00	\$13,795.0000	\$6,897.50		\$0.00

Total Bid:	As Read:			
	As Calculated:	\$162,078.75	\$197,229.90	\$0.00
	% Over/Under:	(27.53)%	(11.82)%	

Instructions for BLR 12315 - Page 1 of 1

Note: Instructions should not be included when the form is submitted.

This form shall be used for a Local Public Agency (LPA) to record bids taken for a project. For more information see Chapter 12 of the Bureau of Local Roads and Street Manual (BLRS Manual).

Bidder Number Drop Down	Select the number of bidders for the project from the drop down. NOTE: This drop down will alter the size of the form. Click the 'Reset' button at the top of the form to restore the original form.
Local Public Agency (LPA)	Insert the name of the LPA.
County	Insert the name of the County in which the LPA is located.
Section Number	Insert the section number without dashes of the project for which bids are being taken.
Letting Date	Insert the date the letting was held.
Approved Engineer's Estimate	No entry necessary; this field is completed based on the items entered under the approved engineer's estimate.
Attended by (IDOT Representative)	Insert the name of the IDOT representative(s) that attended the letting.
Bidder	For each bidder enter the following information:
Bidder's Name	Insert the name of the bidder whose bid appears below.
Bidder's Address	Insert the street address for the bidder listed above.
City, State, Zip	Insert the city, state, and zip code of the address listed above.
Proposal Guarantee	Insert the proposal guarantee for this bidder. For a material letting, this will usually be a cashier's or certified check for not less than 5% of the amount of the bid or as shown in LRS #7 - Bidding Requirements and Conditions for Material Proposals. For construction projects, Local Agency Proposal Bid Bond (BLR 12230) will usually be acceptable.
Terms	Insert the terms, if applicable, for this bid.
Item No.	Insert the number from Schedule of Prices (BLR 12001) or Material Proposal Schedule of Prices (BLR 12240).
Item	Insert the name of the item corresponding with the item number from Schedule of Prices (BLR 12222) or Material Proposal of Prices (BLR 12240).
Delivery	Insert the delivery method for the item listed to the left, if applicable.
Unit	Insert the unit of measure for the item listed to the left.
Quantity	Insert the quantity of the item listed to the left.
Unit Price	Insert the engineer's estimated unit cost for the item listed to the left.
Total	This field is automatically calculated; no entry necessary. This is the unit price multiplied by the quantity.
For each bidder enter:	
Unit Price	Enter the bidder's unit price for the item listed to the left, from the submitted bidding documents.
Total	This is a calculated field; no entry necessary. It is the bidders submitted unit price multiplied by the bidder's unit cost.
As Read	Insert the total bid price from the bidder's documents. This will be what the bidder calculated, not what the LPA calculates.
As Calculated	No entry necessary; this will be the sum of the totals listed above for each item. This will be the calculated bid.
Add/Remove Pay Items	Use the +/- buttons to add/remove pay items.

Distribution

Submit one original to district office with the successful bidder's documents.



COVER SHEET

Proposal Submitted By:

Contractor's Name

Contractor's Address

City

State

Zip Code

STATE OF ILLINOIS

Local Public Agency

County

Section Number

Route(s) (Street/Road Name)

Type of Funds

Proposal Only Proposal and Plans Proposal only, plans are separate

Submitted/Approved

For Local Public Agency:

For a County and Road District Project

Submitted/Approved

Highway Commissioner Signature & Date

Submitted/Approved

County Engineer/Superintendent of Highways Signature & Date

4/12/24"/>

For a Municipal Project

Submitted/Approved/Passed

Signature & Date

Official Title

Department of Transportation

Released for bid based on limited review

Regional Engineer Signature & Date

Note: All proposal documents, including Proposal Guaranty Checks or Proposal Bid Bonds, should be stapled together to prevent loss when bids are processed.

Local Public Agency	County	Section Number	Route(s) (Street/Road Name)
Champaign Co. Highway Dept.	Champaign	23-00469-00-RS	Salt Dome & Metcad Parking Lot

NOTICE TO BIDDERS

Sealed proposals for the project described below will be received at the office of Champaign County Highway Department
Name of Office
1605 East Main Street, Urbana, IL 61802 until 10:00 AM on 04/30/24
Address Time Date

Sealed proposals will be opened and read publicly at the office of Champaign County Highway Department
Name of Office
1605 East Main Street, Urbana, IL 61802 at 10:00 AM on 04/30/24
Address Time Date

DESCRIPTION OF WORK

Location	Project Length
Salt Dome Parking Lot (301 Art Bartell Rd) and Metcad Parking Lot (1905 E. Main, Urbana)	3552 SY

Proposed Improvement
Salt Dome: Work will consist of placing hot-mix asphalt over the existing parking lot aggregate base. HMA pavement shall consist of 2.25" of polymerized binder course and 1.75" of polymerized surface course.
Metcad: Mill the existing asphalt surface 2", class D patch, and place 2" of HMA surface course and paint pavement markings.

1. Plans and proposal forms will be available in the office of
Champaign County Highway Department, 1605 East Main Street, Urbana, IL 61802.
Plan sets will cost of \$25.00 each.

2. Prequalification
If checked, the 2 apparent as read low bidders must file within 24 hours after the letting an "Affidavit of Availability" (Form BC 57) in triplicate, showing all uncompleted contracts awarded to them and all low bids pending award for Federal, State, County, Municipal and private work. One original shall be filed with the Awarding Authority and two originals with the IDOT District Office.
3. The Awarding Authority reserves the right to waive technicalities and to reject any or all proposals as provided in BLRS Special Provision for Bidding Requirements and Conditions for Contract Proposals.
4. The following BLR Forms shall be returned by the bidder to the Awarding Authority:
 - a. Local Public Agency Formal Contract Proposal (BLR 12200)
 - b. Schedule of Prices (BLR 12201)
 - c. Proposal Bid Bond (BLR 12230) (if applicable)
 - d. Apprenticeship or Training Program Certification (BLR 12325) (do not use for project with Federal funds.)
 - e. Affidavit of Illinois Business Office (BLR 12326) (do not use for project with Federal funds)
5. The quantities appearing in the bid schedule are approximate and are prepared for the comparison of bids. Payment to the Contractor will be made only for the actual quantities of work performed and accepted or materials furnished according to the contract. The scheduled quantities of work to be done and materials to be furnished may be increased, decreased or omitted as hereinafter provided.
6. Submission of a bid shall be conclusive assurance and warranty the bidder has examined the plans and understands all requirements for the performance of work. The bidder will be responsible for all errors in the proposal resulting from failure or neglect to conduct an in depth examination. The Awarding Authority will, in no case, be responsible for any costs, expenses, losses or changes in anticipated profits resulting from such failure or neglect of the bidder.
7. The bidder shall take no advantage of any error or omission in the proposal and advertised contract.
8. If a special envelope is supplied by the Awarding Authority, each proposal should be submitted in that envelope furnished by the Awarding Agency and the blank spaces on the envelope shall be filled in correctly to clearly indicate its contents. When an envelope other than the special one furnished by the Awarding Authority is used, it shall be marked to clearly indicate its contents. When sent by mail, the sealed proposal shall be addressed to the Awarding Authority at the address and in care of the official in whose office the bids are to be received. All proposals shall be filed prior to the time and at the place specified in the Notice to Bidders. Proposals received after the time specified will be returned to the bidder unopened.
9. Permission will be given to a bidder to withdraw a proposal if the bidder makes the request in writing or in person before the time for

opening proposals.

Local Public Agency	County	Section Number	Route(s) (Street/Road Name)
Champaign Co. Highway Dept.	Champaign	23-00469-00-RS	Salt Dome & Metcad Parking Lo

PROPOSAL

- Proposal of _____
Contractor's Name _____
Contractor's Address _____
- The plans for the proposed work are those prepared by Champaign County Highway Department and approved by the Department of Transportation on _____.
- The specifications referred to herein are those prepared by the Department of Transportation and designated as "Standard Specifications for Road and Bridge Construction" and the " Supplemental Specifications and Recurring Special Provisions" thereto, adopted and in effect on the date of invitation for bids.
- The undersigned agrees to accept, as part of the contract, the applicable Special Provisions indicated on the "Check Sheet for Recurring Special Provisions" contained in this proposal.
- The undersigned agrees to complete the work within _____ working days or by 08/31/24 unless additional time is granted in accordance with the specifications.
- The successful bidder at the time of execution of the contract Will be required to deposit a contract bond for the full amount of the award. When a contract bond is not required, the proposal guaranty check will be held in lieu thereof. If this proposal is accepted and the undersigned fails to execute a contract and contract bond as required, it is hereby agreed that the Bid Bond of check shall be forfeited to the Awarding Authority.
- Each pay item should have a unit price and a total price. If no total price is shown or if there is a discrepancy between the products of the unit price multiplied by the quantity, the unit price shall govern. If a unit price is omitted, the total price will be divided by the quantity in order to establish a unit price. A bid may be declared unacceptable if neither a unit price nor a total price is shown.
- The undersigned submits herewith the schedule of prices on BLR 12201 covering the work to be performed under this contract.
- The undersigned further agrees that if awarded the contract for the sections contained in the combinations on BLR 12201, the work shall be in accordance with the requirements of each individual proposal for the multiple bid specified in the Schedule for Multiple Bids below.
- A proposal guaranty in the proper amount, as specified in BLRS Special Provision for Bidding Requirements and Conditions for Contract Proposals, will be required. Bid Bonds Will be allowed as a proposal guaranty. Accompanying this proposal is either a bid bond, if allowed, on Department form BLR 12230 or a proposal guaranty check, complying with the specifications, made payable to: _____ Treasurer of Champaign County.
The amount of the check is _____ (_____).

Attach Cashier's Check or Certified Check Here

In the event that one proposal guaranty check is intended to cover two or more bid proposals, the amount must be equal to the sum of the proposal guaranties which would be required for each individual bid proposal. If the proposal guaranty check is placed in another bid proposal, state below where it may be found.

The proposal guaranty check will be found in the bid proposal for: Section Number _____.

Local Public Agency	County	Section Number	Route(s) (Street/Road Name)
Champaign Co. Highway Dept.	Champaign	23-00469-00-RS	Salt Dome & Metcad Parking Lot

CONTRACTOR CERTIFICATIONS

The certifications hereinafter made by the bidder are each a material representation of fact upon which reliance is placed should the Department enter into the contract with the bidder.

- Debt Delinquency.** The bidder or contractor or subcontractor, respectively, certifies that it is not delinquent in the payment of any tax administered by the Department of Revenue unless the individual or other entity is contesting, in accordance with the procedure established by the appropriate Revenue Act, its liability for the tax or the amount of the tax. Making a false statement voids the contract and allows the Department to recover all amounts paid to the individual or entity under the contract in a civil action.
- Bid-Rigging or Bid Rotating.** The bidder or contractor or subcontractor, respectively, certifies that it is not barred from contracting with the Department by reason of a violation of either 720 ILCS 5/33E-3 or 720 ILCS 5/33E-4.

A violation of section 33E-3 would be represented by a conviction of the crime of bid-rigging which, in addition to Class 3 felony sentencing, provides that any person convicted of this offense, or any similar offense of any state or the United States which contains the same elements as this offense shall be barred for 5 years from the date of conviction from contracting with any unit of State or local government. No corporation shall be barred from contracting with any unit of State or local government as a result of a conviction under this Section of any employee or agent of such corporation if the employee so convicted is no longer employed by the corporation: (1) it has been finally adjudicated not guilty or (2) if it demonstrates to the governmental entity with which it seeks to contract that entity finds that the commission of the offense was neither authorized, requested, commanded, nor performed by a director, officer or a high managerial agent on behalf of the corporation.

A violation of Section 33E-4 would be represented by a conviction of the crime of bid-rotating which, in addition to Class 2 felony sentencing, provides that any person convicted of this offense or any similar offense of any state or the United States which contains the same elements as this offense shall be permanently barred from contracting with any unit of State of Local government. No corporation shall be barred from contracting with any unit of State or Local government as a result of a conviction under this Section of any employee or agent of such corporation if the employee so convicted is no longer employed by the corporation and: (1) it has been finally adjudicated not guilty or (2) if it demonstrates to the governmental entity with which it seeks to contract and that entity finds that the commission of the offense was neither authorized, requested, commanded, nor performed by a director, officer or a high managerial agent on behalf of the corporation.

- Bribery.** The bidder or contractor or subcontractor, respectively, certifies that, it has not been convicted of bribery or attempting to bribe an officer or employee of the State of Illinois or any unit of local government, nor has the firm made an admission of guilt of such conduct which is a matter of record, nor has an official, agent, or employee of the firm committed bribery or attempted bribery on behalf of the firm and pursuant to the direction or authorization of a responsible official of the firm.
- Interim Suspension or Suspension.** The bidder or contractor or subcontractor, respectively, certifies that it is not currently under a suspension as defined in Subpart I of Title 44 Subtitle A Chapter III Part 6 of the Illinois Administrative code. Furthermore, if suspended prior to completion of this work, the contract or contracts executed for the completion of this work may be canceled.

Local Public Agency	County	Section Number	Route(s) (Street/Road Name)
Champaign Co. Highway Dept.	Champaign	23-00469-00-RS	Salt Dome & Metcad Parking L

SIGNATURES

(If an individual)

Bidder Signature & Date

Business Address

City State Zip Code

(If a partnership)

Firm Name

Signature & Date

Title

Business Address

City State Zip Code

Insert the Names and Addresses of all Partners

(If a corporation)

Corporate Name

Signature & Date

Title

Business Address

City State Zip Code

Insert Names of Officers

President

Attest:

Secretary

Secretary

Treasurer



Contractor's Name

Contractor's Address

City

State

Zip Code

Local Public Agency

County

Section Number

Route(s) (Street/Road Name)

Schedule for Multiple Bids

Combination Letter	Section Included in Combinations	Total

Schedule for Single Bid

(For complete information covering these items, see plans and specifications.)

Item Number	Items	Unit	Quantity	Unit Price	Total
40600275	BIT MATLS, PRIME COAT	POUND	7992		
40600290	BIT MATLS, TACK COAT	POUND	2750		
40603240	POLY HMA BIND, IL 19.0, N90	TON	448		
40604152	POLY HMA SC, IL 9.5, C, N70	TON	835		
42400800	DETECTABLE WARNINGS	SQ FT	18		
44000157	HMA SURF REM 2"	SQ YD	4336		
44201723	CLASS D PATCHES, TY IV, 6"	SQ YD	128		
67100100	MOBILIZATION	L. SUM	1		
78001100	PAINT PVT MARK L&S	SQ FT	13		
78001110	PAINT PVT MARK LINE, 4"	FOOT	1965		
X7010216	TRAF CONT & PROT, SPL	L. SUM	1		
Bidder's Total Proposal					

1. Each pay item should have a unit price and a total price.
2. If no total price is shown or if there is a discrepancy between the product of the unit price multiplied by the quantity, the unit price shall govern.
3. If a unit price is omitted, the total price will be divided by the quantity in order to establish a unit price.
4. A bid may be declared unacceptable if neither a unit price or total price is shown.



Local Public Agency Proposal Bid Bond

Local Public Agency: Champaign County Highway Dept. County: Champaign Section Number: 23-00469-00-RS

WE, _____ as PRINCIPAL, and _____ as SURETY, are held jointly, severally and firmly bound unto the above Local Public Agency (hereafter referred to as "LPA") in the penal sum of 5% of the total bid price, or for the amount specified in the proposal documents in effect on the date of invitation for bids, whichever is the lesser sum. We bind ourselves, our heirs, executors, administrators, successors, and assigns, jointly pay to the LPA this sum under the conditions of this instrument.

WHEREAS THE CONDITION OF THE FOREGOING OBLIGATION IS SUCH that, the said PRINCIPAL is submitting a written proposal to the LPA acting through its awarding authority for the construction of the work designated as the above section.

THEREFORE if the proposal is accepted and a contract awarded to the PRINCIPAL by the LPA for the above designated section and the PRINCIPAL shall within fifteen (15) days after award enter into a formal contract, furnish surety guaranteeing the faithful performance of the work, and furnish evidence of the required insurance coverage, all as provided in the "Standard Specifications for Road and Bridge Construction" and applicable Supplemental Specifications, then this obligation shall become void; otherwise it shall remain in full force and effect.

IN THE EVENT the LPA determines the PRINCIPAL has failed to enter into a formal contract in compliance with any requirements set forth in the preceding paragraph, then the LPA acting through its awarding authority shall immediately be entitled to recover the full penal sum set out above, together with all court costs, all attorney fees, and any other expense of recovery.

IN TESTIMONY WHEREOF, the said PRINCIPAL and the said SURETY have caused this instrument to be signed by their respective officers this _____ of _____ Day Month and Year

Principal signature block: Company Name, Signature & Date, Title

Principal signature block: Company Name, Signature & Date, Title

(If Principal is a joint venture of two or more contractors, the company names, and authorized signatures of each contractor must be affixed.)

Surety signature block: Name of Surety

Surety signature block: Signature of Attorney-in-Fact Signature & Date

STATE OF IL COUNTY OF

I _____, a Notary Public in and for said county do hereby certify that

(Insert names of individuals signing on behalf of PRINCIPAL & SURETY)

who are each personally known to me to be the same persons whose names are subscribed to the foregoing instrument on behalf of PRINCIPAL and SURETY, appeared before me this day in person and acknowledged respectively, that they signed and delivered said instruments as their free and voluntary act for the uses and purposes therein set forth.

Given under my hand and notarial seal this _____ day of _____ Month and Year

(SEAL, if required by the LPA)

Notary Public Signature & Date

Date commission expires _____

Local Public Agency

County

Section Number

Champaign County Highway Dept.

Champaign

23-00469-00-RS

ELECTRONIC BID BOND

Electronic bid bond is allowed (box must be checked by LPA if electronic bid bond is allowed)

The Principal may submit an electronic bid bond, in lieu of completing the above section of the Proposal Bid Bond Form. By providing an electronic bid bond ID code and signing below, the Principal is ensuring the identified electronic bid bond has been executed and the Principal and Surety are firmly bound unto the LPA under the conditions of the bid bond as shown above. (If PRINCIPAL is a joint venture of two or more contractors, an electronic bid bond ID code, company/Bidder name title and date must be affixed for each contractor in the venture.)

Electronic Bid Bond ID Code

--	--	--	--	--	--	--	--	--	--	--	--	--	--	--

Company/Bidder Name

--

Signature & Date

--

Title

--



Contract Bond

Local Public Agency	County	Street Name/Road Name	Section Number
Champaign County Highway Dept.	Champaign	Salt Dome Parking Lot	23-00469-00-RS

Bond information to be returned to Local Public Agency at 1605 East Main Street, Urbana IL 61802
Complete Address

We, _____
Contractor's Name and Address

a/an _____ organized under the laws of the State of _____ as PRINCIPAL, and
State

Surety Name and Address

as SURETY, are held and firmly bound unto the above Local Public Agency (hereafter referred to as "LPA") in the penal sum of

Dollars (_____) lawful money of the United States, to be paid to said LPA, the payment of which we bind ourselves, successors and assigns jointly to pay to the LPA this sum under the conditions of this instrument.

WHEREAS, THE CONDITION OF THE FOREGOING OBLIGATION IS SUCH that the said Principal has entered into a written contract with the LPA acting through its awarding authority for the construction of work on the above sections, which contract is hereby referred to and made a part hereof, as if written herein at length, and whereby the said Principal has promised and agreed to perform said work in accordance with the terms of said contract, and has promised to pay all sums of money due for any labor, materials, apparatus, fixtures or machinery furnished to such Principal for the purpose of performing such work and has further agreed to pay all direct and indirect damages to any person, firm, company or corporation to whom any money may be due from the Principal, subcontractor or otherwise for any such labor, materials, apparatus, fixtures or machinery so furnished and that suit may be maintained on such bond by any such person, firm, company or corporation for the recovery of any such money.

NOW, THEREFORE, if the said Principal shall perform said work in accordance with the terms of said contract, and shall pay all sums of money due or to become due for any labor, materials, apparatus, fixtures or machinery furnished to it for the purpose of constructing such work, and shall commence and complete the work within the time prescribed in said contract, and shall pay and discharge all damages, direct and indirect, that may be suffered or sustained on account of such work during the time of the performance thereof and until the said work shall have been accepted, and shall hold the LPA and its awarding authority harmless on account of any such damages and shall in all respects fully and faithfully comply with all the provisions, conditions and requirements of said contract, then this obligation shall be void; otherwise it shall remain in full force and effect.

IN TESTIMONY WHEREOF, the said PRINCIPAL and the said SURETY have caused this instrument to be signed by their respective agents this _____ day of _____
Day Month and Year

PRINCIPAL

Company Name

Company Name

By
Signature & Date

By
Signature & Date

Attest
Signature & Date

Attest
Signature & Date

(If PRINCIPAL is a joint venture of two or more contractors, the company names and authorized signature of each contractor must be affixed.)

STATE OF IL
COUNTY OF _____

I, _____, a Notary Public in and for said county, do hereby certify that
Notary Name

Insert name of Individuals signing on behalf of PRINCIPAL

who is/are each personally known to me to be the same person(s) whose name(s) is/are subscribed to the foregoing instrument on behalf of PRINCIPAL, appeared before me this day in person and acknowledged respectively, that he/she/they signed and delivered said instrument freely and voluntarily for the uses and purposes therein set forth.

Given under my hand and notarial seal this _____ day of _____
Day Month, Year

(SEAL)

Notary Public Signature & Date

[Signature box]

Date commission expires _____

SURETY

Name of Surety

[Name of Surety box]

Title

By:

[Title box]

STATE OF IL
COUNTY OF _____

I, _____, a Notary Public in and for said county, do hereby certify that
Notary Name

Insert name of Individuals signing on behalf of SURETY

who is/are each personally known to me to be the same person(s) whose name(s) is/are subscribed to the foregoing instrument on behalf of SURETY, appeared before me this day in person and acknowledged respectively, that he/she/they signed and delivered said instrument freely and voluntarily for the uses and purposes therein set forth.

Given under my hand and notarial seal this _____ day of _____
Day Month, Year

(SEAL)

Notary Public Signature & Date

[Signature box]

Date commission expires _____

Approved this _____ day of _____
Day Month, Year

Attest:

Local Public Agency Clerk Signature & Date

[Local Public Agency Clerk Signature box]

Awarding Authority

[Awarding Authority box]

Awarding Authority Signature & Date

[Awarding Authority Signature box]

Local Public Agency Type Clerk



Apprenticeship and Training Program Certification

Local Public Agency	County	Street Name/Road Name	Section Number
Champaign County Highway Dept.	Champaign	Salt Dome Parking Lot	23-00469-00-RS

All contractors are required to complete the following certification

- For this contract proposal or for all bidding groups in this deliver and install proposal.
- For the following deliver and install bidding groups in this material proposal.

Illinois Department of Transportation policy, adopted in accordance with the provisions of the Illinois Highway Code, requires this contract to be awarded to the lowest responsive and responsible bidder. The award decision is subject to approval by the Department. In addition to all other responsibility factors, this contract or deliver and install proposal requires all bidders and all bidder's subcontractors to disclose participation in apprenticeship or training programs that are (1) approved by and registered with the United States Department of Labor's Bureau of Apprenticeship and Training, and (2) applicable to the work of the above indicated proposals or groups. Therefore, all bidders are required to complete the following certification:

1. Except as provided in paragraph 4 below, the undersigned bidder certifies that it is a participant, either as an individual or as part of a group program, in an approved apprenticeship or training program applicable to each type of work or craft that the bidder will perform with its own employees.
2. The undersigned bidder further certifies, for work to be performed by subcontract, that each of its subcontractors either (A) is, at the time of such bid, participating in an approved, applicable apprenticeship or training program; or (B) will, prior to commencement of performance of work pursuant to this contract, establish participation in an approved apprenticeship or training program applicable to the work of the subcontract.
3. The undersigned bidder, by inclusion in the list in the space below, certifies the official name of each program sponsor holding the Certificate of Registration for all of the types of work or crafts in which the bidder is a participant and that will be performed with the bidder's employees. Types of work or craft that will be subcontracted shall be included and listed as subcontract work. The list shall also indicate any type of work or craft job category for which there is no applicable apprenticeship or training program available.

4. Except for any work identified above, if any bidder or subcontractor shall perform all or part of the work of the contract or deliver and install proposal solely by individual owners, partners or members and not by employees to whom the payment of prevailing rates of wages would be required, check the following box, and identify the owner/operator workforces and positions of ownership.

The requirements of this certification and disclosure are a material part of the contract, and the contractor shall require this certification provision to be included in all approved subcontracts. The bidder is responsible for making a complete report and shall make certain that each type of work or craft job category that will be utilized on the project is accounted for and listed. The Department at any time before or afterward may require the production of a copy of each applicable Certificate of Registration issued by the United States Department of Labor evidencing such participation by the contractor and any or all of its subcontractors. In order to fulfill the participation requirement, it shall not be necessary that any applicable program sponsor be currently taking or that it will take applications for apprenticeship, training or employment during the performance of the work of this contract or deliver and install proposal.

Bidder	Signature & Date		
<div style="border: 1px solid black; height: 20px;"></div>	<div style="border: 1px solid black; height: 40px;"></div>		
Title			
<div style="border: 1px solid black; height: 20px;"></div>			
Address	City	State	Zip Code
<div style="border: 1px solid black; height: 20px;"></div>	<div style="border: 1px solid black; height: 20px;"></div>	<div style="border: 1px solid black; height: 20px;"></div>	<div style="border: 1px solid black; height: 20px;"></div>



Affidavit of Illinois Business Office

Local Public Agency	County	Street Name/Road Name	Section Number
Champaign County Highway Dept.	Champaign	Salt Dome Parking Lot	23-00469-00-RS

I, _____ of _____, _____,
Name of Affiant City of Affiant State of Affiant
 being first duly sworn upon oath, state as follows:

1. That I am the _____ of _____.
Officer or Position Bidder
2. That I have personal knowledge of the facts herein stated.
3. That, if selected under the proposal described above, _____, will maintain a business office in the
Bidder
 State of Illinois, which will be located in Champaign County, Illinois.
County
4. That this business office will serve as the primary place of employment for any persons employed in the construction contemplated by this proposal.
5. That this Affidavit is given as a requirement of state law as provided in Section 30-22(8) of the Illinois Procurement Code.

Signature & Date

Print Name of Affiant

Notary Public

State of IL
 County _____

Signed (or subscribed or attested) before me on _____ by
(date)

_____, authorized agent(s) of
(name/s of person/s)

Bidder

(SEAL)

Notary Public Signature & Date

My commission expires _____

INDEX TO SPECIAL PROVISIONS

- Intent of Section
- Description of Work
- Working Days and Completion Date
- Traffic Control
- Polymerized Bituminous Materials Mixtures
- Anti-Strip Additives
- Class D Patches, Type IV, 6"
- Construction Layout
- Status of Utilities
- Contact Information
- Champaign County Prevailing Wage Rates
- Index for Supplemental Specifications and Recurring Special Provisions
- Check Sheet for Recurring Special Provisions
- BDE Special Provisions Checksheet
 - Compensable Delay Costs
 - Hot-Mix Asphalt
 - Performance Graded Asphalt Binder
 - Vehicle and Equipment Warning Lights
- LR Special Provisions
 - Insurance
 - Local Quality Assurance / Quality Management QC/QA
 - Emulsified Asphalts
 - Required Cold Milled Textured Surface
- Construction Plans
 - Location Map
 - Summary of Quantities
 - Salt Dome Parking Lot Proposed Plan
 - Salt Dome Quantities
 - Metcad Parking Lot Proposed Plan Sheets
 - Metcad Parking Lot Quantities
 - HMA Mixture Requirement Table
 - Highway Standards



Local Public Agency	County	Section Number
Champaign County Highway Dept.	Champaign	23-00469-00-RS

The following Special Provision supplement the "Standard Specifications for Road and Bridge Construction", adopted

January 1, 2022, the latest edition of the "Manual on Uniform Traffic Control Devices for Streets and Highways", and the "Manual of Test Procedures of Materials" in effect on the date of invitation of bids, and the Supplemental Specification and Recurring Special Provisions indicated on the Check Sheet included here in which apply to and govern the construction of the above named section, and in case of conflict with any parts, or parts of said Specifications, the said Special Provisions shall take precedence and shall govern.

INTENT OF SECTION:

The intent of this section is twofold:

- 1) to pave the existing parking lot around the Champaign County Highway Department (CCHD) Salt Dome using Hot Mix Asphalt binder and surface course, and
- 2) to mill, resurface, and paint the Metcad Parking Lot.

DESCRIPTION OF WORK

The work on this project consists of the following:

Salt Dome Parking Lot:

- a. Work by CCHD: Pavement removal at 10" depth of the existing HMA pavement and base
- b. Work by CCHD: Place and compact Subbase Granular Material, Type B, 6"
- c. Contractor: Hot Mix Asphalt paving
 Polymer HMA Binder Course, IL-19.0 N90 at 2.25" thickness
 Polymer HMA Surface Course IL-9.5, Mix C, N70 at 1.75" thickness

Metcad Parking Lot:

- a. Work by CCHD: Remove 3 parking blocks in NW corner.
- b. Contractor:
 - i. Mill parking lot 2"
 - ii. Class D Patch
 - iii. Pave parking lot 2"
 - iv. Paint pavement marking lines and symbols

WORKING DAYS & COMPLETION DATE

All work on this contract shall be completed by August 31, 2024.

The Salt Dome Parking Lot shall be completed in 5 working days.

The Metcad Parking Lot shall be completed in 5 working days, including the pavement markings. The two projects are not required to be consecutive in scheduling.

If the Contractor chooses to work at both sites simultaneously, the working days for both lots will be enforced. This would mean the Contractor would have 5 working days to complete the entire project. If the Contractor would choose to work at only one site at a time, then he would have 10 working days to complete the entire project.

TRAFFIC CONTROL

Traffic control shall be done in accordance with the applicable sections of the Standard Specifications for Road and Bridge Construction, the applicable guidelines contained in the Illinois Manual on Traffic Control Devices for Streets and Highways, these Special Provisions and any special details and Highway Standards contained herein.

Champaign County Highway Dept.

Champaign

23-00469-00-RS

Traffic Control Plan:

The Salt Dome Parking Lot can be closed to traffic throughout construction. Due to the County doing the removal and aggregate base work, the County requests 14 days notice for the paving project to ensure it is prepared for the Contractor. Contact is Jenni Marner at 217-384-3800.

The Metcad Parking Lot can be closed to traffic throughout construction. Metcad staff and users will need a minimum of 3 working days of notice prior to allowing the lot to be closed. This can be accomplished by contacting Jenni Marner at 217-384-3800.

Utilize barricades with lights, to secure the parking lot adequately for the Contractor and prevent public traffic on the lot during construction.

At no time, shall this location be closed to traffic beyond a reasonable time, allowing for weather related delays. The Contractor shall work diligently to complete all work in a timely manner.

Traffic Control Standards: 701901

Basis of Payment:

All work involved in complying with the TRAFFIC CONTROL PLAN will be paid for at the contract unit price per lump sum for TRAFFIC CONTROL AND PROTECTION, SPECIAL, and no additional payment will be allowed.

POLYMERIZED BITUMINOUS MATERIALS MIXTURES

The asphalt cement to be used in base course and surface course mix designs is SBS PG 70-22 (see Table 406H for details).

ANTI-STRIP ADDITIVES

The cost of anti-strip additive shall be included in the bid price for Hot Mix Asphalt mix, as applicable, and no additional compensation will be allowed.

CLASS D PATCHES, TYPE IV, 6"

This work will be done in accordance with Section 442 of the Standard Specifications. The requirement in 442.08(c) is waived for this project. The saw-cutting of the pavement shall be full depth and will not be paid for separately.

CONSTRUCTION LAYOUT

Any unknown section corners or other survey monuments uncovered during construction should be preserved by the Contractor for evaluation by the Township or Engineer.

All layout necessary for the completion of all pay items will be provided by the Contractor.

This work shall be considered as included in the contract and no additional payment will be allowed.

Local Public Agency

County

Section Number

Champaign County Highway Dept.

Champaign

23-00469-00-RS

STATUS OF UTILITIES

Utility adjustments or relocations should not be required by this project. The Illinois Underground Utility Facilities Damage Prevention Act requires persons excavating to contact the one call system (J.U.L.I.E. 800-892-0123 or 811) before digging.

CONTACT INFORMATION

Jenni Marner - Champaign County Highway Department

Phone: 217-384-3800

Email: jmarner@champaigncountyil.gov

Champaign County Prevailing Wage Rates posted on 3/19/2024

Trade Title	Rg	Type	C	Base	Foreman	Overtime					Pension	Vac	Trng	Other Ins	Add OT 1.5x owed	Add OT 2.0x owed
						M-F	Sa	Su	Hol	H/W						
ASBESTOS ABT-GEN	All	BLD		35.62	36.87	1.5	1.5	2.0	2.0	7.75	19.09	0.00	0.90	0.00	0.00	0.00
ASBESTOS ABT-MEC	All	BLD		26.45	27.45	1.5	1.5	2.0	2.0	10.20	8.75	0.00	0.50	0.00	0.00	0.00
BOILERMAKER	All	BLD		43.54	46.54	1.5	1.5	2.0	2.0	7.07	24.29	0.00	2.18	0.00	16.38	32.76
BRICK MASON	All	BLD		36.59	38.79	1.5	1.5	2.0	2.0	9.60	16.67	0.00	0.96		0.00	0.00
CARPENTER	All	BLD		38.17	40.42	1.5	1.5	2.0	2.0	9.45	18.48	0.00	0.79	0.00	13.97	27.93
CARPENTER	All	HWY		38.17	39.92	1.5	1.5	2.0	2.0	9.45	21.15	0.00	0.76	0.00	0.00	0.00
CEMENT MASON	All	BLD		38.00	40.50	1.5	1.5	2.0	2.0	10.00	11.79	0.00	0.50		0.00	0.00
CEMENT MASON	All	HWY		38.00	40.00	1.5	1.5	2.0	2.0	10.50	13.56	0.00	0.50	0.00	0.00	0.00
CERAMIC TILE FINISHER	All	BLD		34.27		1.5	1.5	2.0	2.0	9.60	12.70	0.00	0.55	0.00	0.00	0.00
ELECTRIC PWR EQMT OP	All	ALL		52.63	62.45	1.5	1.5	2.0	2.0	8.58	14.74	0.00	0.79	0.00	0.00	0.00
ELECTRIC PWR GRNDMAN	All	ALL		35.76	62.45	1.5	1.5	2.0	2.0	8.07	10.01	0.00	0.54	0.00	0.00	0.00
ELECTRIC PWR LINEMAN	All	ALL		58.58	62.45	1.5	1.5	2.0	2.0	8.76	16.40	0.00	0.88	0.00	0.00	0.00
ELECTRIC PWR TRK DRV	All	ALL		37.53	62.45	1.5	1.5	2.0	2.0	8.13	10.51	0.00	0.57	0.00	0.00	0.00
ELECTRICIAN	All	BLD		47.06	51.77	1.5	1.5	2.0	2.0	8.35	12.49	0.00	0.71	0.00	1.06	2.12
ELECTRONIC SYSTEM TECH	All	BLD		35.29	38.29	1.5	1.5	2.0	2.0	8.35	12.21	0.00	0.40	0.00	0.53	1.06
ELEVATOR CONSTRUCTOR	All	BLD		55.57	62.52	2.0	2.0	2.0	2.0	16.17	20.96	4.45	0.75		0.00	0.00
FENCE ERECTOR	All	ALL		36.08	38.08	1.5	1.5	2.0	2.0	12.14	15.75	0.00	1.11	0.00	15.75	15.75
GLAZIER	All	BLD		38.60	40.60	1.5	1.5	2.0	2.0	7.85	13.77	0.00	0.68	0.00	0.00	0.00
HEAT/FROST INSULATOR	All	BLD		34.90	36.40	1.5	1.5	2.0	2.0	8.49	13.79	0.00	0.30	0.65	0.00	0.00
IRON WORKER	All	BLD		36.08	38.08	1.5	1.5	2.0	2.0	12.14	15.75	0.00	1.11	0.00	15.75	15.75
IRON WORKER	All	HWY		38.54	40.54	1.5	1.5	2.0	2.0	12.14	15.75	0.00	1.11	0.00	15.75	15.75
LABORER	All	BLD		32.62	33.87	1.5	1.5	2.0	2.0	7.75	19.09	0.00	0.80	0.00	0.00	0.00
LABORER	All	HWY		35.87	36.87	1.5	1.5	2.0	2.0	7.75	19.42	0.00	0.80	0.00	0.00	0.00
LATHER	All	BLD		38.17	40.42	1.5	1.5	2.0	2.0	9.45	18.48	0.00	0.79	0.00	13.97	27.93
MACHINIST	All	BLD		55.74	59.74	1.5	1.5	2.0	2.0	9.93	8.95	1.85	1.47		0.00	0.00
MARBLE FINISHER	All	BLD		34.27		1.5	1.5	2.0	2.0	9.60	12.70	0.00	0.55	0.00	0.00	0.00
MARBLE MASON	All	BLD		35.83		1.5	1.5	2.0	2.0	9.60	12.70	0.00	0.55	0.00	0.00	0.00

Champaign County Prevailing Wage Rates posted on 3/19/2024

MILLWRIGHT	All	BLD		35.58	37.83	1.5	1.5	2.0	2.0	9.45	21.54	0.00	0.79	0.00	15.50	30.99
MILLWRIGHT	All	HWY		40.10	41.85	1.5	1.5	2.0	2.0	9.45	22.34	0.00	0.76	0.00	0.00	0.00
OPERATING ENGINEER	All	ALL	1	45.15	48.15	1.5	1.5	2.0	2.0	11.85	12.80	0.00	1.35		0.00	0.00
OPERATING ENGINEER	All	ALL	2	30.05	48.15	1.5	1.5	2.0	2.0	11.85	12.80	0.00	1.35	0.00	0.00	0.00
OPERATING ENGINEER	All	ALL	3	47.15	48.15	1.5	1.5	2.0	2.0	11.85	12.80	0.00	1.35	0.00	0.00	0.00
PAINTER	All	ALL		38.47	39.97	1.5	1.5	2.0	2.0	9.85	8.17	0.00	0.60	0.00	0.00	0.00
PAINTER - SIGNS	All	ALL		38.47	39.97	1.5	1.5	2.0	2.0	9.85	8.17	0.00	0.60	0.00	0.00	0.00
PILEDRIIVER	All	BLD		39.17	41.42	1.5	1.5	2.0	2.0	9.45	18.48	0.00	0.79	0.00	13.97	27.93
PILEDRIIVER	All	HWY		39.17	40.92	1.5	1.5	2.0	2.0	9.45	21.15	0.00	0.76	0.00	0.00	0.00
PIPEFITTER	All	BLD		50.35	53.47	1.5	1.5	2.0	2.0	9.25	11.14	0.00	2.66		0.00	0.00
PLASTERER	All	BLD		37.05	39.05	1.5	1.5	2.0	2.0	10.00	14.14	0.00	0.50	0.00	0.00	0.00
PLUMBER	All	BLD		50.35	53.47	1.5	1.5	2.0	2.0	9.25	11.14	0.00	2.66		0.00	0.00
ROOFER	All	BLD		37.00	40.00	1.5	1.5	2.0	2.0	10.77	9.56	0.00	0.91	0.00	0.00	0.00
SHEETMETAL WORKER	All	BLD		42.73	45.23	1.5	1.5	2.0	2.0	10.80	15.97	0.00	0.55	2.09	0.00	0.00
SPRINKLER FITTER	All	BLD		47.09	50.09	1.5	1.5	2.0	2.0	11.45	14.92	0.00	0.52		0.00	0.00
STONE MASON	All	BLD		36.59	38.79	1.5	1.5	2.0	2.0	9.60	16.67	0.00	0.96	0.00	0.00	0.00
TERRAZZO FINISHER	All	BLD		34.27		1.5	1.5	2.0	2.0	9.60	12.70	0.00	0.55	0.00	0.00	0.00
TERRAZZO MASON	All	BLD		35.83		1.5	1.5	2.0	2.0	9.60	12.70	0.00	0.55	0.00	0.00	0.00
TILE MASON	All	BLD		35.83		1.5	1.5	2.0	2.0	9.60	12.70	0.00	0.55	0.00	0.00	0.00
TRUCK DRIVER	All	ALL	1	42.17	46.53	1.5	1.5	2.0	2.0	15.39	7.45	0.00	0.25	0.00	0.00	0.00
TRUCK DRIVER	All	ALL	2	42.76	46.53	1.5	1.5	2.0	2.0	15.39	7.45	0.00	0.25	0.00	0.00	0.00
TRUCK DRIVER	All	ALL	3	43.03	46.53	1.5	1.5	2.0	2.0	15.39	7.45	0.00	0.25	0.00	0.00	0.00
TRUCK DRIVER	All	ALL	4	43.42	46.53	1.5	1.5	2.0	2.0	15.39	7.45	0.00	0.25	0.00	0.00	0.00
TRUCK DRIVER	All	ALL	5	44.52	46.53	1.5	1.5	2.0	2.0	15.39	7.45	0.00	0.25	0.00	0.00	0.00
TRUCK DRIVER	All	O&C	1	33.74	37.22	1.5	1.5	2.0	2.0	15.39	7.45	0.00	0.25	0.00	0.00	0.00
TRUCK DRIVER	All	O&C	2	34.21	37.22	1.5	1.5	2.0	2.0	15.39	7.45	0.00	0.25	0.00	0.00	0.00
TRUCK DRIVER	All	O&C	3	34.42	37.22	1.5	1.5	2.0	2.0	15.39	7.45	0.00	0.25	0.00	0.00	0.00
TRUCK DRIVER	All	O&C	4	34.74	37.22	1.5	1.5	2.0	2.0	15.39	7.45	0.00	0.25	0.00	0.00	0.00
TRUCK DRIVER	All	O&C	5	35.62	37.22	1.5	1.5	2.0	2.0	15.39	7.45	0.00	0.25	0.00	0.00	0.00
TUCK POINTER	All	BLD		36.59	38.79	1.5	1.5	2.0	2.0	9.60	16.67	0.00	0.96	0.00	0.00	0.00

Champaign County Prevailing Wage Rates posted on 3/19/2024

Legend

Rg Region

Type Trade Type - All,Highway,Building,Floating,Oil & Chip,Rivers

C Class

Base Base Wage Rate

OT M-F Unless otherwise noted, OT pay is required for any hour greater than 8 worked each day, Mon through Fri. The number listed is the multiple of the base wage.

OT Sa Overtime pay required for every hour worked on Saturdays

OT Su Overtime pay required for every hour worked on Sundays

OT Hol Overtime pay required for every hour worked on Holidays

H/W Health/Welfare benefit

Vac Vacation

Trng Training

Other Ins Employer hourly cost for any other type(s) of insurance provided for benefit of worker.

Explanations CHAMPAIGN COUNTY

The following list is considered as those days for which holiday rates of wages for work performed apply: New Years Day, Memorial Day, Fourth of July, Labor Day, Thanksgiving Day, Christmas Day and Veterans Day in some classifications/counties. Generally, any of these holidays which fall on a Sunday is celebrated on the following Monday. This then makes work performed on that Monday payable at the appropriate overtime rate for holiday pay. Common practice in a given local may alter certain days of celebration. If in doubt, please check with IDOL.

Oil and chip resealing (O&C) means the application of road oils and liquid asphalt to coat an existing road surface, followed by application of aggregate chips or gravel to coated surface, and subsequent rolling of material to seal the surface.

EXPLANATION OF CLASSES

ASBESTOS - GENERAL - removal of asbestos material/mold and hazardous materials from any place in a building, including mechanical systems where those mechanical systems are to be removed. This includes the removal of asbestos materials/mold and hazardous materials from ductwork or pipes in a building when the building is to be demolished at the time or at some close future date.

ASBESTOS - MECHANICAL - removal of asbestos material from mechanical systems, such as pipes, ducts, and boilers, where the mechanical systems are to remain.

CERAMIC TILE FINISHER, MARBLE FINISHER, TERRAZZO FINISHER

Assisting, helping or supporting the tile, marble and terrazzo mechanic by performing their historic and traditional work assignments required to complete the proper installation of the work covered by said crafts. The term "Ceramic" is used for

Champaign County Prevailing Wage Rates posted on 3/19/2024

naming the classification only and is in no way a limitation of the product handled. Ceramic takes into consideration most hard tiles.

ELECTRONIC SYSTEMS TECHNICIAN

Installation, service and maintenance of low-voltage systems which utilizes the transmission and/or transference of voice, sound, vision, or digital for commercial, education, security and entertainment purposes for the following: TV monitoring and surveillance, background/foreground music, intercom and telephone interconnect, field programming, inventory control systems, microwave transmission, multi-media, multiplex, radio page, school, intercom and sound burglar alarms and low voltage master clock systems.

Excluded from this classification are energy management systems, life safety systems, supervisory controls and data acquisition systems not intrinsic with the above listed systems, fire alarm systems, nurse call systems and raceways exceeding fifteen feet in length.

TRUCK DRIVER - BUILDING, HEAVY AND HIGHWAY CONSTRUCTION Class 1. Drivers on 2 axle trucks hauling less than 9 ton. Air compressor and welding machines and brooms, including those pulled by separate units, truck driver helpers, warehouse employees, mechanic helpers, greasers and tiremen, pickup trucks when hauling materials, tools, or workers to and from and on-the-job site, and fork lifts up to 6,000 lb. capacity.

Class 2. Two or three axle trucks hauling more than 9 ton but hauling less than 16 ton. A-frame winch trucks, hydrolift trucks, vactor trucks or similar equipment when used for transportation purposes. Fork lifts over 6,000 lb. capacity, winch trucks, four axle combination units, and ticket writers.

Class 3. Two, three or four axle trucks hauling 16 ton or more. Drivers on water pulls, articulated dump trucks, mechanics and working forepersons, and dispatchers. Five axle or more combination units.

Class 4. Low Boy and Oil Distributors.

Class 5. Drivers who require special protective clothing while employed on hazardous waste work.

TRUCK DRIVER - OIL AND CHIP RESEALING ONLY.

This shall encompass laborers, workers and mechanics who drive contractor or subcontractor owned, leased, or hired pickup, dump, service, or oil distributor trucks. The work includes transporting materials and equipment (including but not limited to, oils, aggregate supplies, parts, machinery and tools) to or from the job site; distributing oil or liquid asphalt and aggregate; stock piling material when in connection with the actual oil and chip contract. The Truck Driver (Oil & Chip Resealing) wage classification does not include supplier delivered materials.

OPERATING ENGINEERS - BUILDING, HEAVY AND HIGHWAY CONSTRUCTION Class 1. Draglines, Derricks, Shovels, Gradalls, Mechanics, Tractor Highlift, Tournadozer, Concrete Mixers with Skip, Tournamixer, Two Drum Machine, One Drum Hoist with Tower or Boom, Cableways, Tower Machines, Motor Patrol, Boom Tractor, Boom or Winch Truck, Winch or Hydraulic Boom Truck, Tournapull, Tractor Operating Scoops, Bulldozer, Push Tractor, Asphalt Planer, Finishing Machine on Asphalt, Large Rollers on

Champaign County Prevailing Wage Rates posted on 3/19/2024

Earth, Rollers on Asphalt Mix, Ross Carrier or similar Machine, Gravel Processing Machine, Asphalt Plant Engineer, Paver Operator, Dredging Equipment, or Dredge Engineer, or Dredge Operator, Central Mix Plant Engineer, CMI or similar type machine, Concrete Pump, Truck or Skid Mounted, Engineer or Rock Crusher Plant, Concrete Plant Engineer, Ditching Machine with dual attachment, Tractor Mounted Loaders, Hydro Crane, Standard or Dinkey Locomotives, Scoopmobiles, Euclid Loader, Soil Cement Machine, Back Filler, Elevating Machine, Power Blade, Drilling Machine, including Well Testing, Caissons, Shaft or any similar type drilling machines, Motor Driven Paint Machine, Pipe Cleaning Machine, Pipe Wrapping Machine, Pipe Bending Machine, Apsco Paver, Boring Machine, (Head Equipment Greaser), Barber-Greene Loaders, Formless Paver, (Well Point System), Concrete Spreader, Hydra Ax, Span Saw, Marine Scoops, Brush Mulcher, Brush Burner, Mesh Placer, Tree Mover, Helicopter Crew (3), Piledriver-Skid or Crawler, Stump Remover, Root Rake, Tug Boat Operator, Refrigerating Machine, Freezing Operator, Chair Cart- Self-Propelled, Hydra Seeder, Straw Blower, Power Sub Grader, Bull Float, Finishing Machine, Self-Propelled Pavement Breaker, Lull (or similar type Machine), Two Air Compressors, Compressors hooked in Manifold, Chip Spreader, Mud Cat, Sull-Air, Fork Lifts (except when used for landscaping work), Soil Stabilizer (Seaman Tiller, Bo Mag, Rago Gator, and similar types of equipment), Tube Float, Spray Machine, Curing Machine, Concrete or Asphalt Milling Machine, Snooper Truck-Operator, Backhoe, Farm Tractors (with attachments), 4 Point Lift System (Power Lift or similar type), Skid-Steer (Bob Cat or similar type), Wrecking Shears, Water Blaster.

Class 2. Concrete Mixers without Skips, Rock Crusher, Ditching Machine under 6', Curbing Machine, One Drum Machines without Tower or Boom, Air Tugger, Self-Propelled Concrete Saw, Machine Mounted Post Hole Digger, two to four Generators, Water Pumps or Welding Machines, within 400 feet, Air Compressor 600 cu. ft. and under, Rollers on Aggregate and Seal Coat Surfaces, Fork Lift (when used for landscaping work), Concrete and Blacktop Curb Machine, One Water Pump, Oilers, Air Valves or Steam Valves, One Welding Machine, Truck Jack, Mud Jack, Gunnite Machine, House Elevators when used for hoisting material, Engine Tenders, Fireman, Wagon Drill, Flex Plane, Conveyor, Siphons and Pulsometer, Switchman, Fireman on Paint Pots, Fireman on Asphalt Plants, Distributor Operator on Trucks, Tampers, Self-Propelled Power Broom, Striping Machine (motor driven), Form Tamper, Bulk Cement Plant, Equipment Greaser, Deck Hands, Truck Crane Oiler-Driver, Cement Blimps, Form Grader, Temporary Heat, Throttle Valve, Super Sucker (and similar type of equipment).

Class 3. Power Cranes, Truck or Crawler Crane, Rough Terrain Crane (Cherry Picker), Tower Crane, Overhead Crane.

Other Classifications of Work:

For definitions of classifications not otherwise set out, the Department generally has on file such definitions which are available. If a task to be performed is not subject to one of the classifications of pay set out, the Department will upon being contacted state which neighboring county has such a classification and provide such rate, such rate being deemed to exist by reference in this document. If no neighboring county rate applies to the task, the Department shall undertake a special determination, such special determination being then deemed to have existed under this determination. If a project requires these, or any classification not listed, please contact IDOL at 217-782-1710 for wage rates or clarifications.

LANDSCAPING

Landscaping work falls under the existing classifications for laborer, operating engineer and truck driver. The work performed by landscape plantsman and landscape laborer is covered by the existing classification of laborer. The work performed by landscape operators (regardless of equipment used or its size) is covered by the classifications of operating engineer. The work performed by landscape truck drivers (regardless of size of truck driven) is covered by the classifications of truck driver.

INDEX
FOR
SUPPLEMENTAL SPECIFICATIONS
AND RECURRING SPECIAL PROVISIONS

Adopted January 1, 2024

This index contains a listing of SUPPLEMENTAL SPECIFICATIONS, frequently used RECURRING SPECIAL PROVISIONS, and LOCAL ROADS AND STREETS RECURRING SPECIAL PROVISIONS.

ERRATA Standard Specifications for Road and Bridge Construction
(Adopted 1-1-22) (Revised 1-1-24)

SUPPLEMENTAL SPECIFICATIONS

<u>Std. Spec. Sec.</u>	<u>Page No.</u>
202 Earth and Rock Excavation	1
204 Borrow and Furnished Excavation	2
207 Porous Granular Embankment	3
211 Topsoil and Compost	4
407 Hot-Mix Asphalt Pavement (Full-Depth)	5
420 Portland Cement Concrete Pavement	6
502 Excavation for Structures	7
509 Metal Railings	8
540 Box Culverts	9
542 Pipe Culverts	29
586 Granular Backfill for Structures	34
630 Steel Plate Beam Guardrail	35
644 High Tension Cable Median Barrier	36
665 Woven Wire Fence	37
782 Reflectors	38
801 Electrical Requirements	40
821 Roadway Luminaires	43
1003 Fine Aggregates	44
1004 Coarse Aggregates	45
1010 Finely Divided Minerals	46
1020 Portland Cement Concrete	47
1030 Hot-Mix Asphalt	48
1061 Waterproofing Membrane System	49
1067 Luminaire	50
1097 Reflectors	57



Check Sheet for Recurring Special Provisions

Local Public Agency	County	Section Number
Champaign County Highway Department	Champaign	23-00469-00-RS

Check this box for lettings prior to 01/01/2024.

The Following Recurring Special Provisions Indicated By An "X" Are Applicable To This Contract And Are Included By Reference:

Recurring Special Provisions

<u>Check Sheet #</u>		<u>Page No.</u>
1	<input type="checkbox"/> Additional State Requirements for Federal-Aid Construction Contracts	59
2	<input type="checkbox"/> Subletting of Contracts (Federal-Aid Contracts)	62
3	<input type="checkbox"/> EEO	63
4	<input type="checkbox"/> Specific EEO Responsibilities Non Federal-Aid Contracts	73
5	<input type="checkbox"/> Required Provisions - State Contracts	78
6	<input type="checkbox"/> Asbestos Bearing Pad Removal	84
7	<input type="checkbox"/> Asbestos Waterproofing Membrane and Asbestos HMA Surface Removal	85
8	<input type="checkbox"/> Temporary Stream Crossings and In-Stream Work Pads	86
9	<input type="checkbox"/> Construction Layout Stakes	87
10	<input type="checkbox"/> Use of Geotextile Fabric for Railroad Crossing	90
11	<input type="checkbox"/> Subsealing of Concrete Pavements	92
12	<input type="checkbox"/> Hot-Mix Asphalt Surface Correction	96
13	<input type="checkbox"/> Pavement and Shoulder Resurfacing	98
14	<input type="checkbox"/> Patching with Hot-Mix Asphalt Overlay Removal	99
15	<input type="checkbox"/> Polymer Concrete	101
16	<input type="checkbox"/> Reserved	103
17	<input type="checkbox"/> Bicycle Racks	104
18	<input type="checkbox"/> Temporary Portable Bridge Traffic Signals	106
19	<input type="checkbox"/> Nighttime Inspection of Roadway Lighting	108
20	<input type="checkbox"/> English Substitution of Metric Bolts	109
21	<input type="checkbox"/> Calcium Chloride Accelerator for Portland Cement Concrete	110
22	<input type="checkbox"/> Quality Control of Concrete Mixtures at the Plant	111
23	<input type="checkbox"/> Quality Control/Quality Assurance of Concrete Mixtures	119
24	<input type="checkbox"/> Reserved	135
25	<input type="checkbox"/> Reserved	136
26	<input type="checkbox"/> Temporary Raised Pavement Markers	137
27	<input type="checkbox"/> Restoring Bridge Approach Pavements Using High-Density Foam	138
28	<input type="checkbox"/> Portland Cement Concrete Inlay or Overlay	141
29	<input type="checkbox"/> Portland Cement Concrete Partial Depth Hot-Mix Asphalt Patching	145
30	<input type="checkbox"/> Longitudinal Joint and Crack Patching	148
31	<input type="checkbox"/> Concrete Mix Design - Department Provided	150
32	<input type="checkbox"/> Station Numbers in Pavements or Overlays	151

Local Public Agency

County

Section Number

Champaign County Highway Department

Champaign

23-00469-00-RS

The Following Local Roads And Streets Recurring Special Provisions Indicated By An "X" Are Applicable To This Contract And Are Included By Reference:

Local Roads And Streets Recurring Special Provisions

<u>Check Sheet #</u>		<u>Page No.</u>
LRS 1	Reserved	153
LRS 2	<input type="checkbox"/> Furnished Excavation	154
LRS 3	<input checked="" type="checkbox"/> Work Zone Traffic Control Surveillance	155
LRS 4	<input type="checkbox"/> Flaggers in Work Zones	156
LRS 5	<input checked="" type="checkbox"/> Contract Claims	157
LRS 6	<input checked="" type="checkbox"/> Bidding Requirements and Conditions for Contract Proposals	158
LRS 7	<input type="checkbox"/> Bidding Requirements and Conditions for Material Proposals	164
LRS 8	Reserved	170
LRS 9	<input type="checkbox"/> Bituminous Surface Treatments	171
LRS 10	Reserved	175
LRS 11	<input checked="" type="checkbox"/> Employment Practices	176
LRS 12	<input checked="" type="checkbox"/> Wages of Employees on Public Works	178
LRS 13	<input checked="" type="checkbox"/> Selection of Labor	180
LRS 14	<input type="checkbox"/> Paving Brick and Concrete Paver Pavements and Sidewalks	181
LRS 15	<input checked="" type="checkbox"/> Partial Payments	184
LRS 16	<input type="checkbox"/> Protests on Local Lettings	185
LRS 17	<input checked="" type="checkbox"/> Substance Abuse Prevention Program	186
LRS 18	<input type="checkbox"/> Multigrade Cold Mix Asphalt	187
LRS 19	<input type="checkbox"/> Reflective Crack Control Treatment	188

BDE SPECIAL PROVISIONS
For the April 26 and June 14, 2024 Lettings

The following special provisions indicated by a “check mark” are applicable to this contract and will be included by the Project Coordination and Implementation Section of the Bureau of Design & Environment (BDE).

File Name	#		Special Provision Title	Effective	Revised	
	80099	1	<input type="checkbox"/>	Accessible Pedestrian Signals (APS)	April 1, 2003	Jan. 1, 2022
	80274	2	<input type="checkbox"/>	Aggregate Subgrade Improvement	April 1, 2012	April 1, 2022
	80192	3	<input type="checkbox"/>	Automated Flagger Assistance Devices	Jan. 1, 2008	April 1, 2023
	80173	4	<input type="checkbox"/>	Bituminous Materials Cost Adjustments	Nov. 2, 2006	Aug. 1, 2017
	80426	5	<input type="checkbox"/>	Bituminous Surface Treatment with Fog Seal	Jan. 1, 2020	Jan. 1, 2022
*	80241	6	<input type="checkbox"/>	Bridge Demolition Debris	July 1, 2009	
*	50531	7	<input type="checkbox"/>	Building Removal	Sept. 1, 1990	Aug. 1, 2022
*	50261	8	<input type="checkbox"/>	Building Removal with Asbestos Abatement	Sept. 1, 1990	Aug. 1, 2022
	80449	9	<input type="checkbox"/>	Cement, Type II	Aug. 1, 2023	
	80384	10	<input type="checkbox"/>	Compensable Delay Costs	June 2, 2017	April 1, 2019
*	80198	11	<input type="checkbox"/>	Completion Date (via calendar days)	April 1, 2008	
*	80199	12	<input type="checkbox"/>	Completion Date (via calendar days) Plus Working Days	April 1, 2008	
	80453	13	<input type="checkbox"/>	Concrete Sealer	Nov. 1, 2023	
	80261	14	<input type="checkbox"/>	Construction Air Quality – Diesel Retrofit	June 1, 2010	Nov. 1, 2014
	80434	15	<input type="checkbox"/>	Corrugated Plastic Pipe (Culvert and Storm Sewer)	Jan. 1, 2021	
*	80029	16	<input type="checkbox"/>	Disadvantaged Business Enterprise Participation	Sept. 1, 2000	Mar. 2, 2019
	80229	17	<input type="checkbox"/>	Fuel Cost Adjustment	April 1, 2009	Aug. 1, 2017
	80452	18	<input type="checkbox"/>	Full Lane Sealant Waterproofing System	Nov. 1, 2023	
	80447	19	<input type="checkbox"/>	Grading and Shaping Ditches	Jan. 1, 2023	
	80433	20	<input type="checkbox"/>	Green Preformed Thermoplastic Pavement Markings	Jan. 1, 2021	Jan. 1, 2022
	80443	21	<input type="checkbox"/>	High Tension Cable Median Barrier Removal	April 1, 2022	
	80456	22	<input type="checkbox"/>	Hot-Mix Asphalt	Jan. 1, 2024	
	80446	23	<input type="checkbox"/>	Hot-Mix Asphalt - Longitudinal Joint Sealant	Nov. 1, 2022	Aug. 1, 2023
	80438	24	<input type="checkbox"/>	Illinois Works Apprenticeship Initiative – State Funded Contracts	June 2, 2021	April 2, 2024
	80045	25	<input type="checkbox"/>	Material Transfer Device	June 15, 1999	Jan. 1, 2022
	80450	26	<input type="checkbox"/>	Mechanically Stabilized Earth Retaining Walls	Aug. 1, 2023	
	80441	27	<input type="checkbox"/>	Performance Graded Asphalt Binder	Jan. 1, 2023	
	80451	28	<input type="checkbox"/>	Portland Cement Concrete	Aug. 1, 2023	
*	34261	29	<input type="checkbox"/>	Railroad Protective Liability Insurance	Dec. 1, 1986	Jan. 1, 2022
	80455	30	<input type="checkbox"/>	Removal and Disposal of Regulated Substances	Jan. 1, 2024	April 1, 2024
	80445	31	<input type="checkbox"/>	Seeding	Nov. 1, 2022	
	80457	32	<input type="checkbox"/>	Short Term and Temporary Pavement Markings	April 1, 2024	
	80448	33	<input type="checkbox"/>	Source of Supply and Quality Requirements	Jan. 2, 2023	
	80340	34	<input type="checkbox"/>	Speed Display Trailer	April 2, 2014	Jan. 1, 2022
	80127	35	<input type="checkbox"/>	Steel Cost Adjustment	April 2, 2004	Jan. 1, 2022
	80397	36	<input type="checkbox"/>	Subcontractor and DBE Payment Reporting	April 2, 2018	
	80391	37	<input type="checkbox"/>	Subcontractor Mobilization Payments	Nov. 2, 2017	April 1, 2019
	80437	38	<input type="checkbox"/>	Submission of Payroll Records	April 1, 2021	Nov. 2, 2023
	80435	39	<input type="checkbox"/>	Surface Testing of Pavements – IRI	Jan. 1, 2021	Jan. 1, 2023
	80410	40	<input type="checkbox"/>	Traffic Spotters	Jan. 1, 2019	
*	20338	41	<input type="checkbox"/>	Training Special Provisions	Oct. 15, 1975	Sept. 2, 2021
	80429	42	<input type="checkbox"/>	Ultra-Thin Bonded Wearing Course	April 1, 2020	Jan. 1, 2022
	80439	43	<input type="checkbox"/>	Vehicle and Equipment Warning Lights	Nov. 1, 2021	Nov. 1, 2022
	80302	44	<input type="checkbox"/>	Weekly DBE Trucking Reports	June 2, 2012	Nov. 1, 2021
	80454	45	<input type="checkbox"/>	Wood Sign Support	Nov. 1, 2023	
	80427	46	<input type="checkbox"/>	Work Zone Traffic Control Devices	Mar. 2, 2020	
*	80071	47	<input type="checkbox"/>	Working Days	Jan. 1, 2002	

Highlighted items indicate a new or revised special provision for the letting.

An * indicates the special provision requires additional information from the designer, which needs to be submitted separately. The Project Coordination and Implementation Section will then include the information in the applicable special provision.

The following special provisions are in the 2024 Supplemental Specifications and Recurring Special Provisions.

<u>File Name</u>	<u>Special Provision Title</u>	<u>New Location(s)</u>	<u>Effective</u>	<u>Revised</u>
80436	Blended Finely Divided Minerals	Articles 1010.01 & 1010.06	April 1, 2021	
80440	Waterproofing Membrane System	Article 1061.05	Nov. 1, 2021	

COMPENSABLE DELAY COSTS (BDE)

Effective: June 2, 2017

Revised: April 1, 2019

Revise Article 107.40(b) of the Standard Specifications to read:

“(b) Compensation. Compensation will not be allowed for delays, inconveniences, or damages sustained by the Contractor from conflicts with facilities not meeting the above definition; or if a conflict with a utility in an unanticipated location does not cause a shutdown of the work or a documentable reduction in the rate of progress exceeding the limits set herein. The provisions of Article 104.03 notwithstanding, compensation for delays caused by a utility in an unanticipated location will be paid according to the provisions of this Article governing minor and major delays or reduced rate of production which are defined as follows.

- (1) Minor Delay. A minor delay occurs when the work in conflict with the utility in an unanticipated location is completely stopped for more than two hours, but not to exceed two weeks.
- (2) Major Delay. A major delay occurs when the work in conflict with the utility in an unanticipated location is completely stopped for more than two weeks.
- (3) Reduced Rate of Production Delay. A reduced rate of production delay occurs when the rate of production on the work in conflict with the utility in an unanticipated location decreases by more than 25 percent and lasts longer than seven calendar days.”

Revise Article 107.40(c) of the Standard Specifications to read:

“(c) Payment. Payment for Minor, Major, and Reduced Rate of Production Delays will be made as follows.

- (1) Minor Delay. Labor idled which cannot be used on other work will be paid for according to Article 109.04(b)(1) and (2) for the time between start of the delay and the minimum remaining hours in the work shift required by the prevailing practice in the area.

Equipment idled which cannot be used on other work, and which is authorized to standby on the project site by the Engineer, will be paid for according to Article 109.04(b)(4).

- (2) Major Delay. Labor will be the same as for a minor delay.

Equipment will be the same as for a minor delay, except Contractor-owned equipment will be limited to two weeks plus the cost of move-out to either the

Contractor's yard or another job and the cost to re-mobilize, whichever is less. Rental equipment may be paid for longer than two weeks provided the Contractor presents adequate support to the Department (including lease agreement) to show retaining equipment on the job is the most economical course to follow and in the public interest.

- (3) Reduced Rate of Production Delay. The Contractor will be compensated for the reduced productivity for labor and equipment time in excess of the 25 percent threshold for that portion of the delay in excess of seven calendar days. Determination of compensation will be in accordance with Article 104.02, except labor and material additives will not be permitted.

Payment for escalated material costs, escalated labor costs, extended project overhead, and extended traffic control will be determined according to Article 109.13."

Revise Article 108.04(b) of the Standard Specifications to read:

"(b) No working day will be charged under the following conditions.

- (1) When adverse weather prevents work on the controlling item.
- (2) When job conditions due to recent weather prevent work on the controlling item.
- (3) When conduct or lack of conduct by the Department or its consultants, representatives, officers, agents, or employees; delay by the Department in making the site available; or delay in furnishing any items required to be furnished to the Contractor by the Department prevents work on the controlling item.
- (4) When delays caused by utility or railroad adjustments prevent work on the controlling item.
- (5) When strikes, lock-outs, extraordinary delays in transportation, or inability to procure critical materials prevent work on the controlling item, as long as these delays are not due to any fault of the Contractor.
- (6) When any condition over which the Contractor has no control prevents work on the controlling item."

Revise Article 109.09(f) of the Standard Specifications to read:

"(f) Basis of Payment. After resolution of a claim in favor of the Contractor, any adjustment in time required for the work will be made according to Section 108. Any adjustment in the costs to be paid will be made for direct labor, direct materials, direct equipment, direct jobsite overhead, direct offsite overhead, and other direct costs allowed by the resolution. Adjustments in costs will not be made for interest charges, loss of anticipated profit, undocumented loss of efficiency, home office overhead and unabsorbed overhead

other than as allowed by Article 109.13, lost opportunity, preparation of claim expenses and other consequential indirect costs regardless of method of calculation.

The above Basis of Payment is an essential element of the contract and the claim cost recovery of the Contractor shall be so limited.”

Add the following to Section 109 of the Standard Specifications.

“109.13 Payment for Contract Delay. Compensation for escalated material costs, escalated labor costs, extended project overhead, and extended traffic control will be allowed when such costs result from a delay meeting the criteria in the following table.

Contract Type	Cause of Delay	Length of Delay
Working Days	Article 108.04(b)(3) or Article 108.04(b)(4)	No working days have been charged for two consecutive weeks.
Completion Date	Article 108.08(b)(1) or Article 108.08(b)(7)	The Contractor has been granted a minimum two week extension of contract time, according to Article 108.08.

Payment for each of the various costs will be according to the following.

- (a) Escalated Material and/or Labor Costs. When the delay causes work, which would have otherwise been completed, to be done after material and/or labor costs have increased, such increases will be paid. Payment for escalated material costs will be limited to the increased costs substantiated by documentation furnished by the Contractor. Payment for escalated labor costs will be limited to those items in Article 109.04(b)(1) and (2), except the 35 percent and 10 percent additives will not be permitted.
- (b) Extended Project Overhead. For the duration of the delay, payment for extended project overhead will be paid as follows.
 - (1) Direct Jobsite and Offsite Overhead. Payment for documented direct jobsite overhead and documented direct offsite overhead, including onsite supervisory and administrative personnel, will be allowed according to the following table.

Original Contract Amount	Supervisory and Administrative Personnel
Up to \$5,000,000	One Project Superintendent
Over \$ 5,000,000 - up to \$25,000,000	One Project Manager, One Project Superintendent or Engineer, and One Clerk
Over \$25,000,000 - up to \$50,000,000	One Project Manager, One Project Superintendent, One Engineer, and

	One Clerk
Over \$50,000,000	One Project Manager, Two Project Superintendents, One Engineer, and One Clerk

(2) Home Office and Unabsorbed Overhead. Payment for home office and unabsorbed overhead will be calculated as 8 percent of the total delay cost.

(c) Extended Traffic Control. Traffic control required for an extended period of time due to the delay will be paid for according to Article 109.04.

When an extended traffic control adjustment is paid under this provision, an adjusted unit price as provided for in Article 701.20(a) for increase or decrease in the value of work by more than ten percent will not be paid.

Upon payment for a contract delay under this provision, the Contractor shall assign subrogation rights to the Department for the Department's efforts of recovery from any other party for monies paid by the Department as a result of any claim under this provision. The Contractor shall fully cooperate with the Department in its efforts to recover from another party any money paid to the Contractor for delay damages under this provision."

80384

HOT-MIX ASPHALT (BDE)

Effective: January 1, 2024

Revise the second paragraph of Articles 1030.07(a)(11) and 1030.08(a)(9) of the Standard Specifications to read:

“When establishing the target density, the HMA maximum theoretical specific gravity (G_{mm}) will be based on the running average of four available Department test results for that project. If less than four G_{mm} test results are available, an average of all available Department test results for that project will be used. The initial G_{mm} will be the last available Department test result from a QMP project. If there is no available Department test result from a QMP project, the Department mix design verification test result will be used as the initial G_{mm} .”

In the Supplemental Specifications, replace the revision for the end of the third paragraph of Article 1030.09(h)(2) with the following:

“When establishing the target density, the HMA maximum theoretical specific gravity (G_{mm}) will be the Department mix design verification test result.”

Revise the tenth paragraph of Article 1030.10 of the Standard Specifications to read:

“Production is not required to stop after a test strip has been constructed.”

80456

PERFORMANCE GRADED ASPHALT BINDER (BDE)

Effective: January 1, 2023

Revise Article 1032.05 of the Standard Specifications to read:

“1032.05 Performance Graded Asphalt Binder. These materials will be accepted according to the Bureau of Materials Policy Memorandum, “Performance Graded Asphalt Binder Qualification Procedure.” The Department will maintain a qualified producer list. These materials shall be free from water and shall not foam when heated to any temperature below the actual flash point. Air blown asphalt, recycle engine oil bottoms (ReOB), and polyphosphoric acid (PPA) modification shall not be used.

When requested, producers shall provide the Engineer with viscosity/temperature relationships for the performance graded asphalt binders delivered and incorporated in the work.

- (a) Performance Graded (PG) Asphalt Binder. The asphalt binder shall meet the requirements of AASHTO M 320, Table 1 “Standard Specification for Performance Graded Asphalt Binder” for the grade shown on the plans and the following.

Test	Parameter
Small Strain Parameter (AASHTO PP 113) BBR, ΔT_c , 40 hrs PAV (40 hrs continuous or 2 PAV at 20 hrs)	-5 °C min.

- (b) Modified Performance Graded (PG) Asphalt Binder. The asphalt binder shall meet the requirements of AASHTO M 320, Table 1 “Standard Specification for Performance Graded Asphalt Binder” for the grade shown on the plans.

Asphalt binder modification shall be performed at the source, as defined in the Bureau of Materials Policy Memorandum, “Performance Graded Asphalt Binder Qualification Procedure.”

Modified asphalt binder shall be safe to handle at asphalt binder production and storage temperatures or HMA construction temperatures. Safety Data Sheets (SDS) shall be provided for all asphalt modifiers.

- (1) Polymer Modification (SB/SBS or SBR). Elastomers shall be added to the base asphalt binder to achieve the specified performance grade and shall be either a styrene-butadiene diblock, triblock copolymer without oil extension, or a styrene-butadiene rubber. The polymer modified asphalt binder shall be smooth, homogeneous, and be according to the requirements shown in Table 1 or 2 for the grade shown on the plans.

Table 1 - Requirements for Styrene-Butadiene Copolymer (SB/SBS) Modified Asphalt Binders		
Test	Asphalt Grade SB/SBS PG 64-28 SB/SBS PG 70-22	Asphalt Grade SB/SBS PG 64-34 SB/SBS PG 70-28 SB/SBS PG 76-22 SB/SBS PG 76-28
Separation of Polymer ITP, "Separation of Polymer from Asphalt Binder" Difference in °F (°C) of the softening point between top and bottom portions	4 (2) max.	4 (2) max.
TESTS ON RESIDUE FROM ROLLING THIN FILM OVEN TEST (AASHTO T 240)		
Elastic Recovery ASTM D 6084, Procedure A, 77 °F (25 °C), 100 mm elongation, %	60 min.	70 min.

Table 2 - Requirements for Styrene-Butadiene Rubber (SBR) Modified Asphalt Binders		
Test	Asphalt Grade SBR PG 64-28 SBR PG 70-22	Asphalt Grade SB/SBS PG 64-34 SB/SBS PG 70-28 SBR PG 76-22 SBR PG 76-28
Separation of Polymer ITP, "Separation of Polymer from Asphalt Binder" Difference in °F (°C) of the softening point between top and bottom portions	4 (2) max.	4 (2) max.
Toughness ASTM D 5801, 77 °F (25 °C), 20 in./min. (500 mm/min.), in.-lbs (N-m)	110 (12.5) min.	110 (12.5) min.
Tenacity ASTM D 5801, 77 °F (25 °C), 20 in./min. (500 mm/min.), in.-lbs (N-m)	75 (8.5) min.	75 (8.5) min.
TESTS ON RESIDUE FROM ROLLING THIN FILM OVEN TEST (AASHTO T 240)		
Elastic Recovery ASTM D 6084, Procedure A, 77 °F (25 °C), 100 mm elongation, %	40 min.	50 min.

- (2) Ground Tire Rubber (GTR) Modification. GTR modification is the addition of recycled ground tire rubber to liquid asphalt binder to achieve the specified performance grade. GTR shall be produced from processing automobile and/or truck tires by the ambient

grinding method or micronizing through a cryogenic process. GTR shall not exceed 1/16 in. (2 mm) in any dimension and shall not contain free metal particles, moisture that would cause foaming of the asphalt, or other foreign materials. A mineral powder (such as talc) meeting the requirements of AASHTO M 17 may be added, up to a maximum of four percent by weight of GTR to reduce sticking and caking of the GTR particles. When tested in accordance with Illinois Modified AASHTO T 27 “Standard Method of Test for Sieve Analysis of Fine and Coarse Aggregates” or AASHTO PP 74 “Standard Practice for Determination of Size and Shape of Glass Beads Used in Traffic Markings by Means of Computerized Optical Method”, a 50 g sample of the GTR shall conform to the following gradation requirements.

Sieve Size	Percent Passing
No. 16 (1.18 mm)	100
No. 30 (600 µm)	95 ± 5
No. 50 (300 µm)	> 20

GTR modified asphalt binder shall be tested for rotational viscosity according to AASHTO T 316 using spindle S27. GTR modified asphalt binder shall be tested for original dynamic shear and RTFO dynamic shear according to AASHTO T 315 using a gap of 2 mm.

The GTR modified asphalt binder shall meet the requirements of Table 3.

Table 3 - Requirements for Ground Tire Rubber (GTR) Modified Asphalt Binders		
Test	Asphalt Grade GTR PG 64-28 GTR PG 70-22	Asphalt Grade GTR PG 76-22 GTR PG 76-28 GTR PG 70-28
TESTS ON RESIDUE FROM ROLLING THIN FILM OVEN TEST (AASHTO T 240)		
Elastic Recovery ASTM D 6084, Procedure A, 77 °F (25 °C), 100 mm elongation, %	60 min.	70 min.

- (3) Softener Modification (SM). Softener modification is the addition of organic compounds, such as engineered flux, bio-oil blends, modified vegetable oils, glycol amines, and fatty acid derivatives, to the base asphalt binder to achieve the specified performance grade. Softeners shall be dissolved, dispersed, or reacted in the asphalt binder to enhance its performance and shall remain compatible with the asphalt binder with no separation. Softeners shall not be added to modified PG asphalt binder as defined in Articles 1032.05(b)(1) or 1032.05(b)(2).

An Attenuated Total Reflectance-Fourier Transform Infrared spectrum (ATR-FTIR) shall be collected for both the softening compound as well as the softener modified

asphalt binder at the dose intended for qualification. The ATR-FTIR spectra shall be collected on unaged softener modified binder, 20-hour Pressurized Aging Vessel (PAV) aged softener modified binder, and 40-hour PAV aged softener modified binder. The ATR-FTIR shall be collected in accordance with Illinois Test Procedure 601. The electronic files spectral files (in one of the following extensions or equivalent: *.SPA, *.SPG, *.IRD, *.IFG, *.CSV, *.SP, *.IRS, *.GAML, *. [0-9], *.IGM, *.ABS, *.DRT, *.SBM, *.RAS) shall be submitted to the Central Bureau of Materials.

Softener modified asphalt binders shall meet the requirements in Table 4.

Test	Asphalt Grade	
	SM PG 46-28	SM PG 46-34
	SM PG 52-28	SM PG 52-34
	SM PG 58-22	SM PG 58-28
	SM PG 64-22	
Small Strain Parameter (AASHTO PP 113) BBR, ΔT_c , 40 hrs PAV (40 hrs continuous or 2 PAV at 20 hrs)	-5°C min.	
Large Strain Parameter (Illinois Modified AASHTO T 391) DSR/LAS Fatigue Property, $\Delta G^* _{peak}$, 40 hrs PAV (40 hrs continuous or 2 PAV at 20 hrs)	≥ 54 %	

The following grades may be specified as tack coats.

Asphalt Grade	Use
PG 58-22, PG 58-28, PG 64-22	Tack Coat

Revise Article 1031.06(c)(1) and 1031.06(c)(2) of the Standard Specifications to read:

“(1) RAP/RAS. When RAP is used alone or RAP is used in conjunction with RAS, the percentage of virgin ABR shall not exceed the amounts listed in the following table.

Ndesign	Binder	Surface	Polymer Modified Binder or Surface ^{3/}
30	30	30	10
50	25	15	10
70	15	10	10
90	10	10	10

1/ For Low ESAL HMA shoulder and stabilized subbase, the RAP/RAS ABR shall not exceed 50 percent of the mixture.

- 2/ When RAP/RAS ABR exceeds 20 percent, the high and low virgin asphalt binder grades shall each be reduced by one grade (i.e. 25 percent ABR would require a virgin asphalt binder grade of PG 64-22 to be reduced to a PG 58-28).
- 3/ The maximum ABR percentages for ground tire rubber (GTR) modified mixes shall be equivalent to the percentages specified for SBS/SBR polymer modified mixes.
- (2) FRAP/RAS. When FRAP is used alone or FRAP is used in conjunction with RAS, the percentage of virgin asphalt binder replacement shall not exceed the amounts listed in the following table.

HMA Mixtures - FRAP/RAS Maximum ABR % ^{1/2/}			
Ndesign	Binder	Surface	Polymer Modified Binder or Surface ^{3/}
30	55	45	15
50	45	40	15
70	45	35	15
90	45	35	15
SMA	--	--	25
IL-4.75	--	--	35

- 1/ For Low ESAL HMA shoulder and stabilized subbase, the FRAP/RAS ABR shall not exceed 50 percent of the mixture.
- 2/ When FRAP/RAS ABR exceeds 20 percent for all mixes, the high and low virgin asphalt binder grades shall each be reduced by one grade (i.e. 25 percent ABR would require a virgin asphalt binder grade of PG 64-22 to be reduced to a PG 58-28).
- 3/ The maximum ABR percentages for GTR modified mixes shall be equivalent to the percentages specified for SBS/SBR polymer modified mixes.”

Add the following to the end of Note 2 of Article 1030.03 of the Standard Specifications.

“A dedicated storage tank for the ground tire rubber (GTR) modified asphalt binder shall be provided. This tank shall be capable of providing continuous mechanical mixing throughout and/or recirculation of the asphalt binder to provide a uniform mixture. The tank shall be heated and capable of maintaining the temperature of the asphalt binder at 300 °F to 350 °F (149 °C to 177 °C). The asphalt binder metering systems of dryer drum plants shall be calibrated with the actual GTR modified asphalt binder material with an accuracy of ±0.40 percent.”

VEHICLE AND EQUIPMENT WARNING LIGHTS (BDE)

Effective: November 1, 2021

Revised: November 1, 2022

Add the following paragraph after the first paragraph of Article 701.08 of the Standard Specifications:

“The Contractor shall equip all vehicles and equipment with high-intensity oscillating, rotating, or flashing, amber or amber-and-white, warning lights which are visible from all directions. In accordance with 625 ILCS 5/12-215, the lights may only be in operation while the vehicle or equipment is engaged in construction operations.”

80439

State of Illinois
Department of Transportation
Bureau of Local Roads and Streets

SPECIAL PROVISION
FOR
INSURANCE

Effective: February 1, 2007
Revised: August 1, 2007

All references to Sections or Articles in this specification shall be construed to mean specific Section or Article of the Standard Specifications for Road and Bridge Construction, adopted by the Department of Transportation.

The Contractor shall name the following entities as additional insured under the Contractor's general liability insurance policy in accordance with Article 107.27:

The entities listed above and their officers, employees, and agents shall be indemnified and held harmless in accordance with Article 107.26.

State of Illinois
 DEPARTMENT OF TRANSPORTATION
 Bureau of Local Roads & Streets
 SPECIAL PROVISION
 FOR
 LOCAL QUALITY ASSURANCE/ QUALITY MANAGEMENT QC/QA
 Effective: January 1, 2022

Replace the first five paragraphs of Article 1030.06 of the Standard Specifications with the following:

“1030.06 Quality Management Program. The Quality Management Program (QMP) will be Quality Control / Quality Assurance (QC/QA) according to the following.”

Delete Article 1030.06(d)(1) of the Standard Specifications.

Revise Article 1030.09(g)(3) of the Standard Specifications to read:

“(3) If core testing is the density verification method, the Contractor shall provide personnel and equipment to collect density verification cores for the Engineer. Core locations will be determined by the Engineer following the document “Hot-Mix Asphalt QC/QA Procedure for Determining Random Density Locations” at density verification intervals defined in Article 1030.09(b). After the Engineer identifies a density verification location and prior to opening to traffic, the Contractor shall cut a 4 in. (100 mm) diameter core. With the approval of the Engineer, the cores may be cut at a later time.”

Revise Article 1030.09(h)(2) of the Standard Specifications to read:

“(2) After final rolling and prior to paving subsequent lifts, the Engineer will identify the random density verification test locations. Cores or nuclear density gauge testing will be used for density verification. The method used for density verification will be as selected below.

Density Verification Method	
<input type="checkbox"/>	Cores
<input checked="" type="checkbox"/>	Nuclear Density Gauge (Correlated when paving ≥ 3,000 tons per mixture)

Density verification test locations will be determined according to the document “Hot-Mix Asphalt QC/QA Procedure for Determining Random Density Locations”. The density testing interval for paving wider than or equal to 3 ft (1 m) will be 0.5 miles (800 m) for lift thicknesses of 3 in. (75 mm) or less and 0.2 miles (320 m) for lift thicknesses greater than 3 in. (75 mm). The density testing interval for paving less than 3 ft (1 m) wide will be 1 mile (1,600 m). If a day’s paving will be less than the prescribed density testing interval, the length of the day’s paving will be the interval for that day. The density testing interval for mixtures used for patching will be 50 patches with a minimum of one test per mixture per project.

If core testing is the density verification method, the Engineer will witness the Contractor coring, and secure and take possession of all density samples at the

density verification locations. The Engineer will test the cores collected by the Contractor for density according to Illinois Modified AASHTO T 166 or AASHTO T 275.

If nuclear density gauge testing is the density verification method, the Engineer will conduct nuclear density gauge tests. The Engineer will follow the density testing procedure detailed in the document "Illinois Modified ASTM D 2950, Standard Test Method for Density of Bituminous Concrete In-Place by Nuclear Method".

A density verification test will be the result of a single core or the average of the nuclear density tests at one location. The results of each density test must be within acceptable limits. The Engineer will promptly notify the Contractor of observed deficiencies."

Revise the seventh paragraph and all subsequent paragraphs in Section D. of the document "Hot-Mix Asphalt QC/QA Initial Daily Plant and Random Samples" to read:

"Mixtures shall be sampled from the truck at the plant by the Contractor following the same procedure used to collect QC mixture samples (Section A). This process will be witnessed by the Engineer who will take custody of the verification sample. Each sample bag with a verification mixture sample will be secured by the Engineer using a locking ID tag. Sample boxes containing the verification mixture sample will be sealed/taped by the Engineer using a security ID label."

REQUIRED COLD MILLED SURFACE TEXTURE

Effective: November 1, 1987
Revised: January 1, 2007

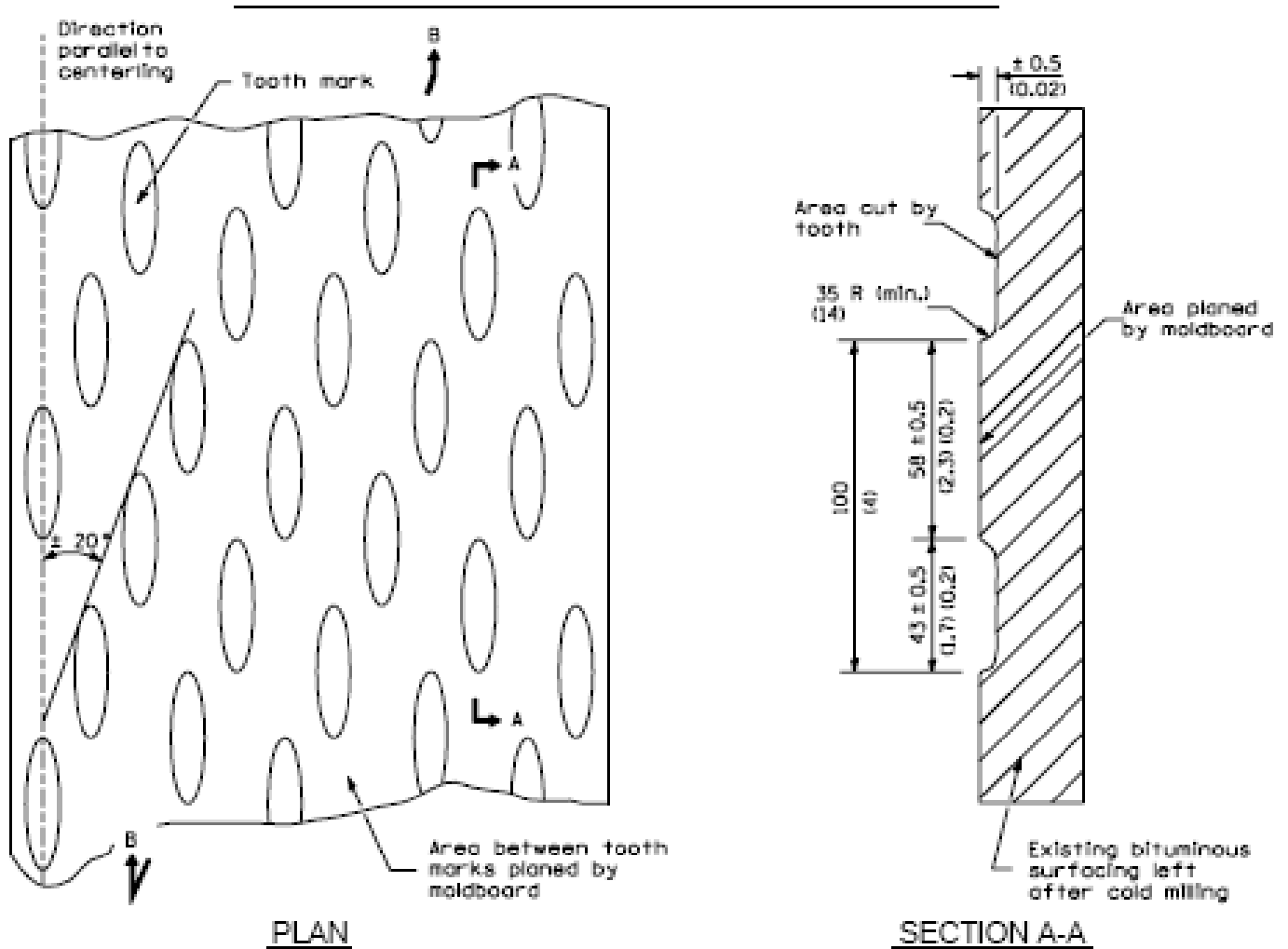

GENERAL NOTES

1. Cold Milling shall consist of two processes:
 - Cutting with carbide teeth mounted on a rotating drum, and
 - Planing with a moldboard mounted immediately behind the cutting drum.
2. Other similar patterns will be acceptable if they consist of a smooth, flat, planed surface interspersed with a portion of discontinuous longitudinal striations.
3. All dimensions are in millimeters (inches) unless otherwise shown.

Location Map

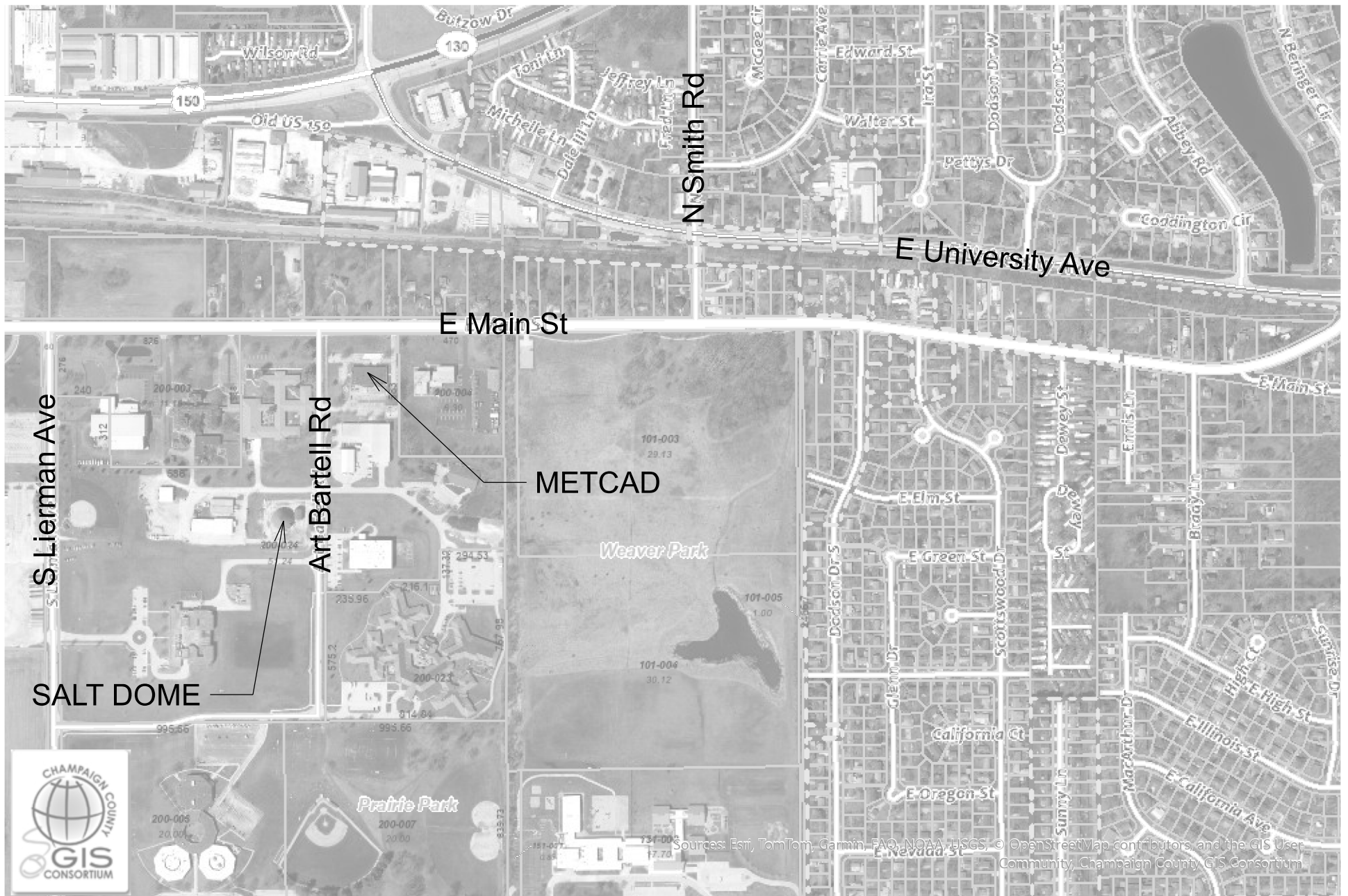

Sources: Esri, TomTom, Garmin, FAO, NOAA, USGS, © OpenStreetMap contributors, and the GIS User Community, Champaign County GIS Consortium

This map was prepared with geographic information system (GIS) data created by the Champaign County GIS Consortium (CCGISC), or other CCGISC member agency. These entities do not warrant or guarantee the accuracy or suitability of GIS data for any purpose. The GIS data within this map is intended to be used as a general index to spatial information and not intended for detailed, site-specific analysis or resolution of legal matters. Users assume all risk arising from the use or misuse of this map and information contained herein. The use of this map constitutes acknowledgement of this disclaimer.



SUMMARY OF QUANTITIES

NUMBER	DESCRIPTION	UNIT	PROJECT TOTALS	SALT DOME QUANTITY	METCAD QUANTITY
40600275	BITUMINOUS MATERIALS, PRIME COAT	POUND	7,992	7,992	
40600290	BITUMINOUS MATERIALS, TACK COAT	POUND	2,783	832	1,951
40603240	POLY HMA BINDER COURSE, IL 19.0, N90	TON	448	448	
40604152	POL HMA SURFACE COURSE, IL 9.5, MIX C, N70	TON	850	364	486
42400800	DETECTABLE WARNINGS	SQ FT	18		18
44000157	HMA SURFACE REMOVAL, 2"	SQ YD	4,336		4,336
44201723	CLASS D PATCHES, TYPE IV, 6"	SQ YD	128		128
67100100	MOBILIZATION	L SUM	1	0.5	0.5
78001100	PAINT PAVEMENT MARKING, L&S	SQ FT	13		13
78001110	PAINT PAVEMENT MARKING LINE, 4"	FOOT	1,965		1,965
X7010216	TRAFFIC CONTROL AND PROTECTION, SPECIAL	L SUM	1	0.5	0.5

NOTE:
 COUNTY WILL REMOVE GUARDRAIL AND TANK. THERE ARE ELECTRICAL PANELS
 AT BOTH LOCATIONS THAT ARE EXPECTED TO BE PRESERVED AND PROTECTED
 BY THE CONTRACTOR.

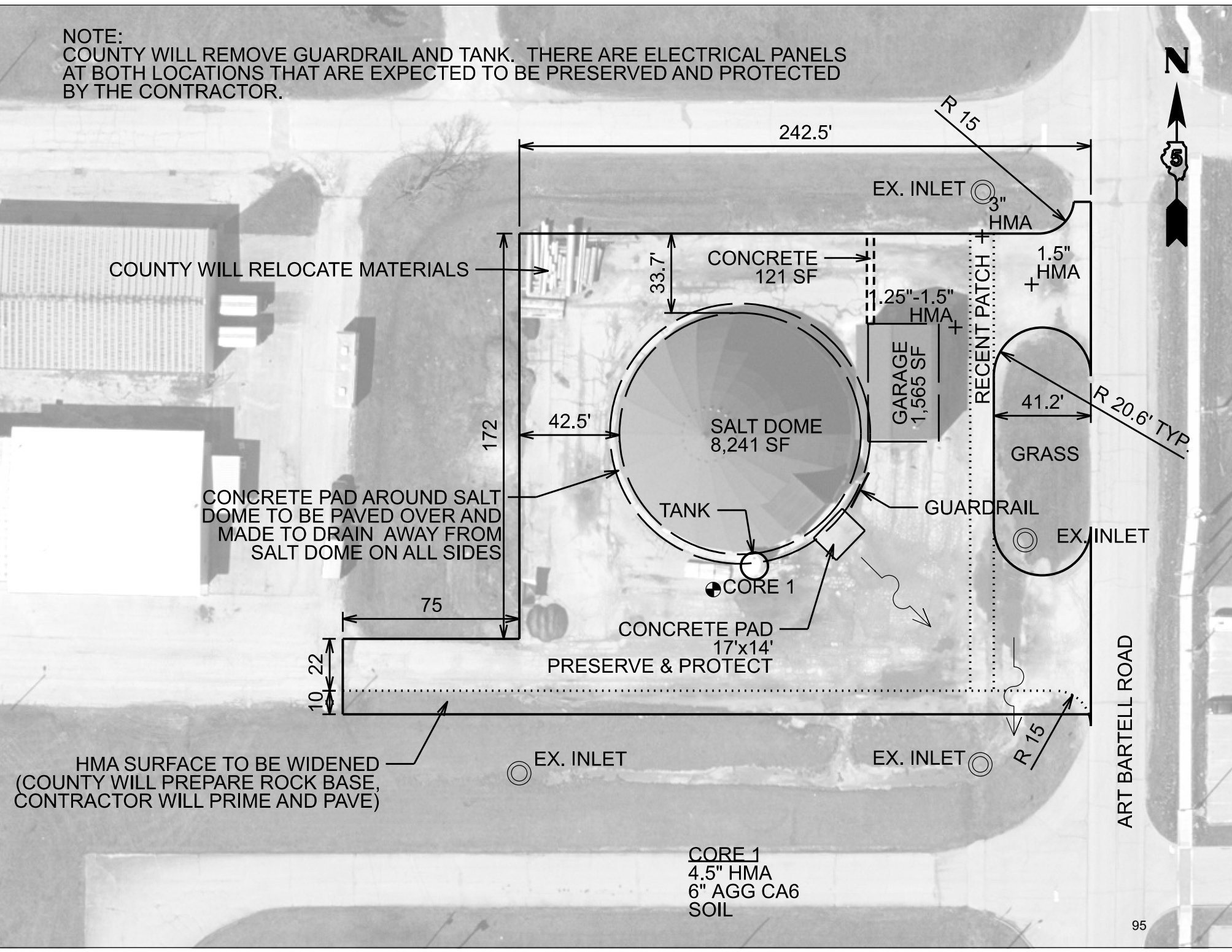
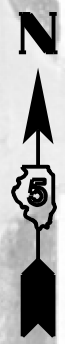

COUNTY WILL RELOCATE MATERIALS

CONCRETE PAD AROUND SALT DOME TO BE PAVED OVER AND MADE TO DRAIN AWAY FROM SALT DOME ON ALL SIDES

HMA SURFACE TO BE WIDENED (COUNTY WILL PREPARE ROCK BASE, CONTRACTOR WILL PRIME AND PAVE)

CORE 1
 4.5" HMA
 6" AGG CA6
 SOIL

ART BARTELL ROAD

**SALT DOME PARKING LOT RESURFACING
SEC. #23-00469-00-RS**

SCHEDULE OF QUANTITIES

Location	40600275	40600290	40603240	40604152
	BIT. MATERIALS PRIME COAT	BIT. MATERIALS TACK COAT	POLY HMA BIND CSE IL 19.0 N90	POLY HMA SURF CSE IL9.5 MIX C, N70
	POUND	POUND	TON	TON
Parking Lot (3552 sy)	7,992	799	448	349
4' wide concrete area around salt dome (144 sy)	0	33	0	15
TOTALS:	7,992	832	448	364

Note:

Application rate for Bituminous Materials, Tack Coat:

Prime Coat, MC 30

0.25 lbs/sf

Tack Coat, NTEA

0.025 lbs/sq.ft.

HMA application rate:

112 lbs/inch-sq.yd.

HMA paving depths, surface course:

1.75 inch

binder course:

2.25 inch

Work to be Completed by the County (prior to Contractor on-site)

Reconnect center East Inlet

Pavement Removal

Excavation for Subbase

Concrete Pad Removal, Replacement and Cure

Placement and Compaction of 12" Agg Base Course (in prep for 4" of HMA)

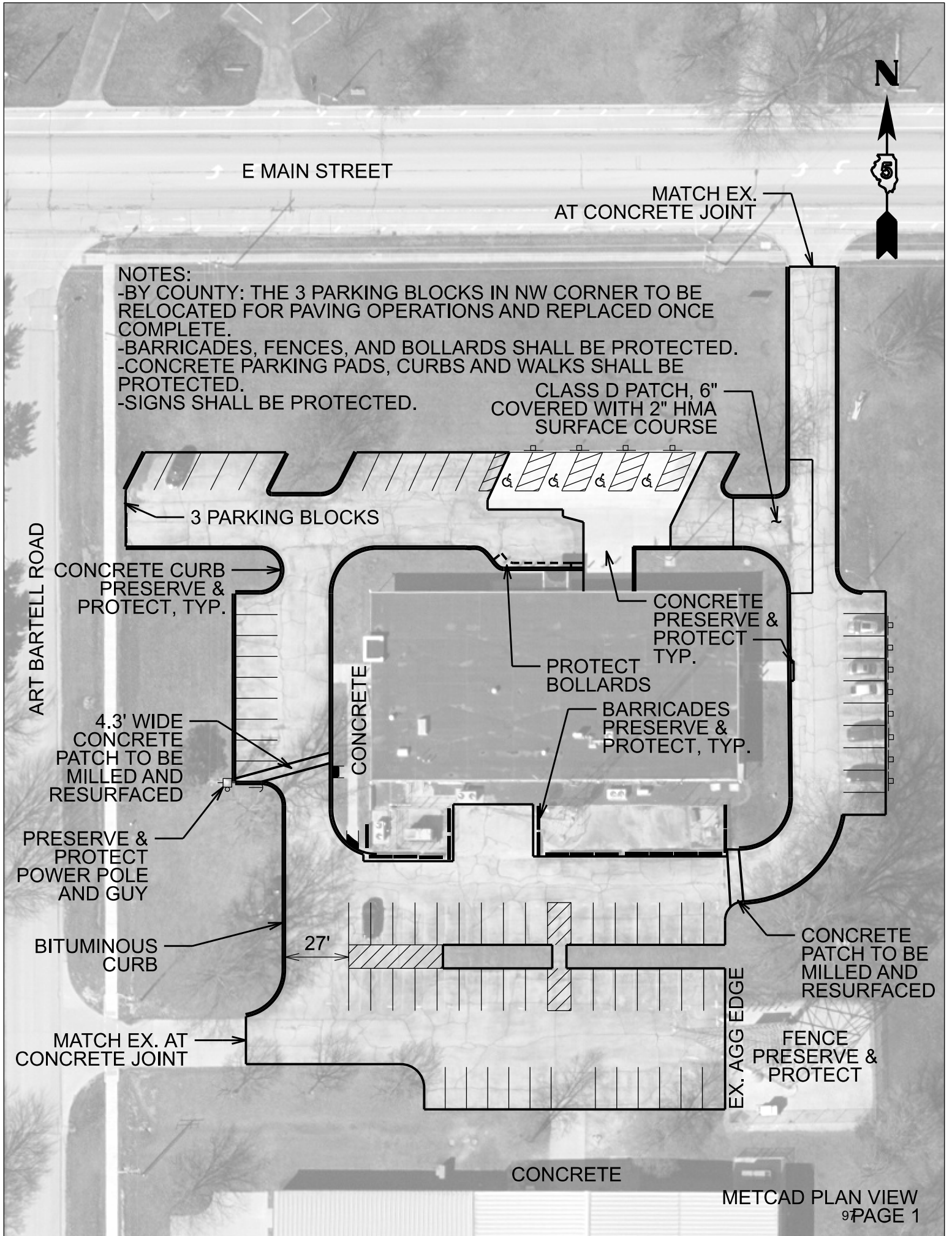

E MAIN STREET

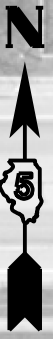

MATCH EX.
AT CONCRETE JOINT

NOTES:

- BY COUNTY: THE 3 PARKING BLOCKS IN NW CORNER TO BE RELOCATED FOR PAVING OPERATIONS AND REPLACED ONCE COMPLETE.
- BARRICADES, FENCES, AND BOLLARDS SHALL BE PROTECTED.
- CONCRETE PARKING PADS, CURBS AND WALKS SHALL BE PROTECTED.
- SIGNS SHALL BE PROTECTED.

CLASS D PATCH, 6"
COVERED WITH 2" HMA
SURFACE COURSE

3 PARKING BLOCKS

ART BARTELL ROAD

CONCRETE CURB
PRESERVE &
PROTECT, TYP.

CONCRETE
PRESERVE &
PROTECT
TYP.

PROTECT
BOLLARDS

BARRICADES
PRESERVE &
PROTECT, TYP.

4.3' WIDE
CONCRETE
PATCH TO BE
MILLED AND
RESURFACED

PRESERVE &
PROTECT
POWER POLE
AND GUY

BITUMINOUS
CURB

27'

CONCRETE
PATCH TO BE
MILLED AND
RESURFACED

MATCH EX. AT
CONCRETE JOINT

EX. AGG EDGE

FENCE
PRESERVE &
PROTECT

CONCRETE

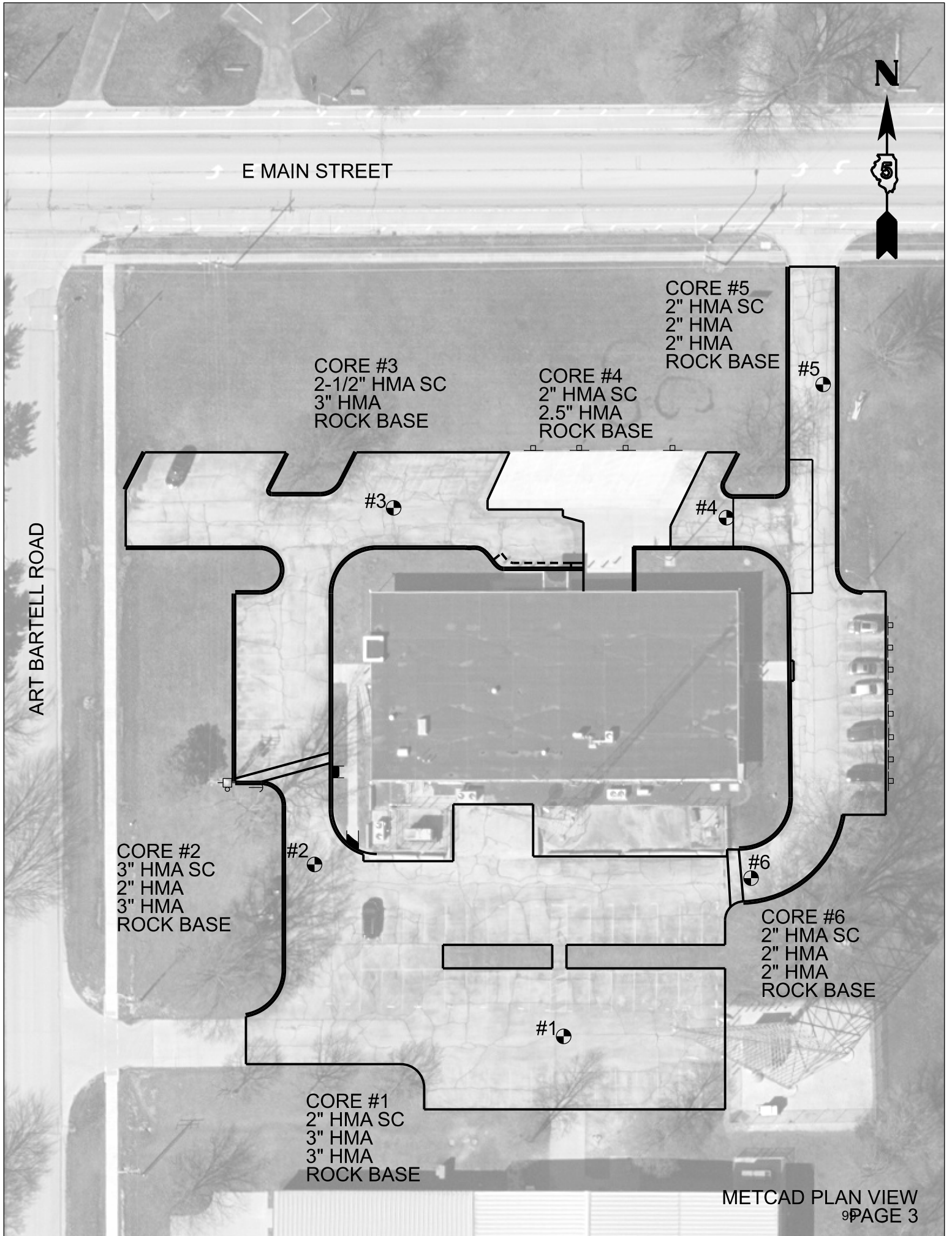

E MAIN STREET

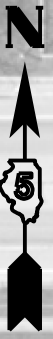

ART BARTELL ROAD

CORE #3
2-1/2" HMA SC
3" HMA
ROCK BASE

CORE #4
2" HMA SC
2.5" HMA
ROCK BASE

CORE #5
2" HMA SC
2" HMA
2" HMA
ROCK BASE

CORE #2
3" HMA SC
2" HMA
3" HMA
ROCK BASE

CORE #6
2" HMA SC
2" HMA
2" HMA
ROCK BASE

CORE #1
2" HMA SC
3" HMA
3" HMA
ROCK BASE

METCAD PARKING LOT RESURFACING
SEC. #23-00469-00-RS
SCHEDULE OF QUANTITIES

LOCATION	44000157	40600290	40604152
	HMA SURFACE REMOVAL, 2"	BIT. MATERIALS TACK COAT	POLY HMA SURF CSE IL9.5 MIX C, N70
	SQ YD	POUND	TON
METCAD PARKING LOT	4336	1951	486

Note:

Application rate for Bituminous Materials, Tack Coat (NTEA)	0.05 lbs/sq.ft.
HMA application rate:	112 lbs/inch-sq.yd.
HMA paving depths, surface course:	2.00 inch

LOCATION	78001110	78001100	42400800
	PAINT PAVEMENT MARKING LINE, 4"	PAINT PAVEMENT MARKING, LETTERS AND SYMBOLS	DETECTABLE WARNINGS
	FOOT	SQ FT	SQ FT
E SIDE: 9*18	162		
N SIDE: 15*18 & DIAG	457.5	12.4	
NW CORNER: 4*18	72		
W SIDE: 8*18	144		18
S SIDE N: 17*18 & DIAG	361.3		
S SIDE MEDIAN:	190.5		
S SIDE MIDDLE: 17*18 & DIAG	361.3		
S SIDE S: 12*18	216		
METCAD PARKING LOT TOTALS:	1965	13	18

NOTE: INTERNATIONAL SYMBOL OF ACCESSIBILITY X 4 ON NORTH SIDE

LOCATION	44201723
	CLASS D PATCHES, TYPE IV, 6"
	SY
METCAD PARKING LOT	128

NOTE: TO BE COVERED BY 2" HMA SURFACE

Work to be Completed by the County

Prior to the Contractor on-site, slide the 3 parking blocks off the paved area.
After the paving operations, place the 3 parking blocks back in place.

SALT DOME & METCAD PARKING LOTS

Location	Salt Dome Parking Lot	Salt Dome and Metcad Parking Lots
Mixture Use	Binder Course 2.25"	Surface Course 1.75" (Salt Dome) and 2" (Metcad)
AC/PG	SBS PG 70-22	SBS PG 70-22
Design Air Voids	4.0% @ Ndes=90	4.0% @ Ndes=70
Mix Comp(Gradation)	IL 19.0	IL 9.5
Friction Aggregate	N.A.	Mix C
Mixture Weight	112	112
Quality Management Program	QC/QA	QC/QA
Sublot Size	N.A.	N.A.
MTD	No	No

Location	Metcad Parking Lot
Mixture Use	Class D Patch 6"
AC/PG	PG 64-22
Design Air Voids	4.0% @ Ndes=70
Mix Comp(Gradation)	IL 19.0
Friction Aggregate	N.A.
Mixture Weight	112
Quality Management Program	QC/QA
Sublot Size	N.A.
MTD	No

NOTE: This patch will be "topped" with the surface course shown above.

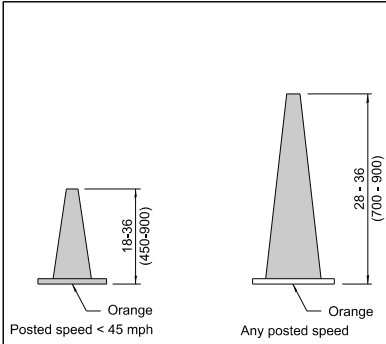

DAYTIME USE

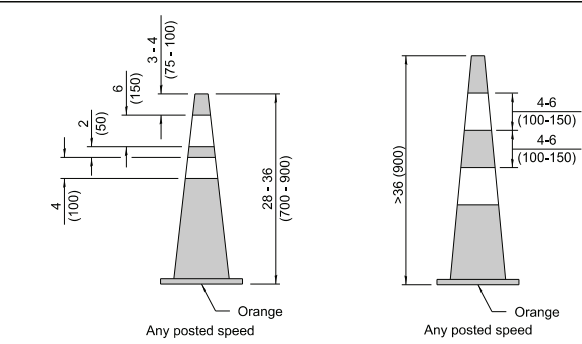

DAY OR NIGHTTIME USE

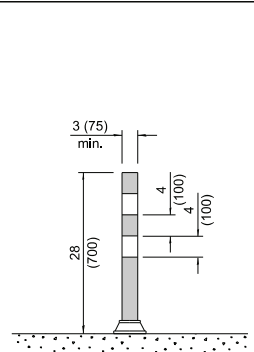

TUBULAR MARKER

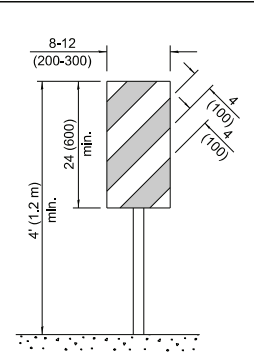

VERTICAL PANEL POST MOUNTED

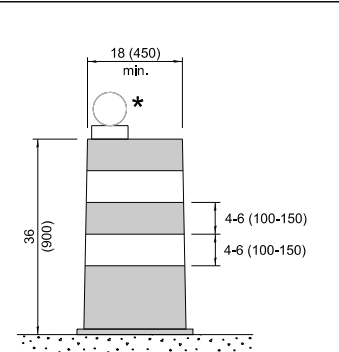

DRUM

CONES

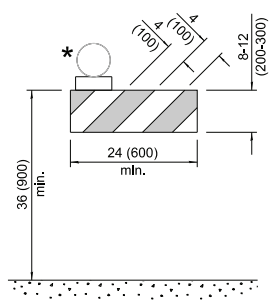

TYPE I BARRICADE

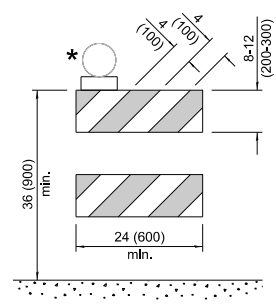

TYPE II BARRICADE

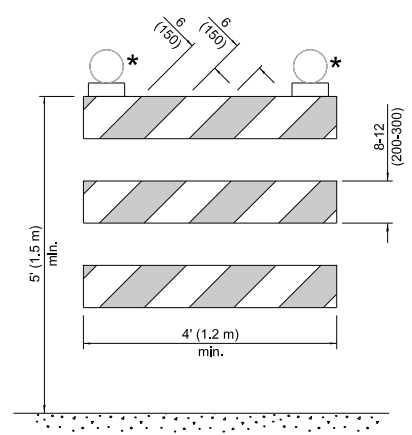

TYPE III BARRICADE

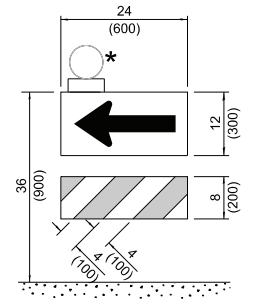

DIRECTION INDICATOR BARRICADE

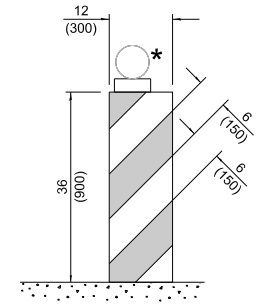

VERTICAL BARRICADE

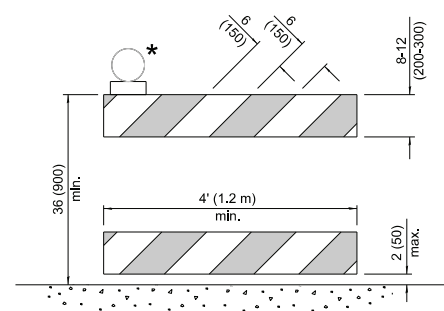

DETECTABLE PEDESTRIAN CHANNELIZING BARRICADE

* Warning lights (if required)

GENERAL NOTES

All heights shown shall be measured above the pavement surface.

All dimensions are in inches (millimeters) unless otherwise shown.

Illinois Department of Transportation

APPROVED January 1, 2024

ENGINEER OF SAFETY PROGRAMS AND ENGINEERING

APPROVED January 1, 2024

ENGINEER OF DESIGN AND ENVIRONMENT

DATE	REVISIONS
1-1-24	Revised Type III Barricade notes (sht. 3) & moved warning light on post mounted signs to top center.
1-1-19	Revised cones usage and added cones > 36" (900 mm) height.

TRAFFIC CONTROL DEVICES

(Sheet 1 of 3)

STANDARD 701901-09

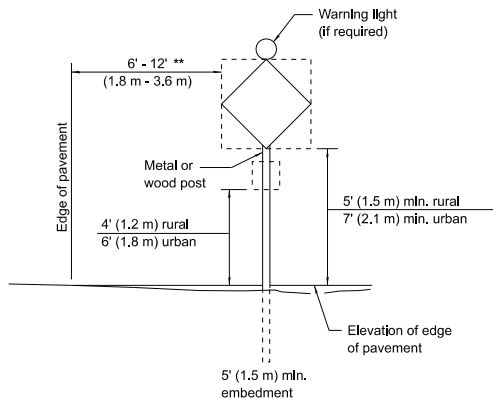

POST MOUNTED SIGNS

** When curb or paved shoulder are present this dimension shall be 24 (600) to the face of curb or 6' (1.8 m) to the outside edge of the paved shoulder.

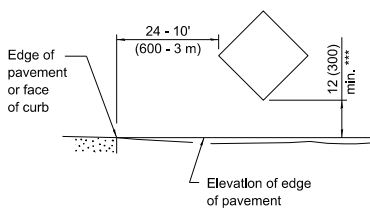

SIGNS ON TEMPORARY SUPPORTS

*** When work operations exceed four days, this dimension shall be 5' (1.5 m) min. If located behind other devices, the height shall be sufficient to be seen completely above the devices.

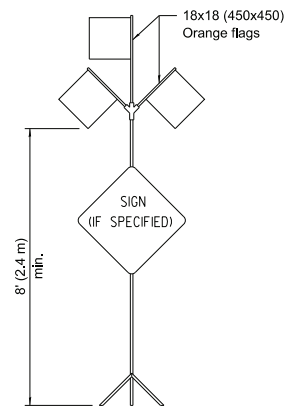

HIGH LEVEL WARNING DEVICE

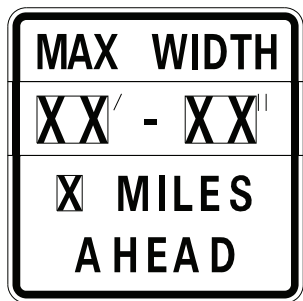

W12-1103-4848

WIDTH RESTRICTION SIGN

XX-XX" width and X miles are variable.

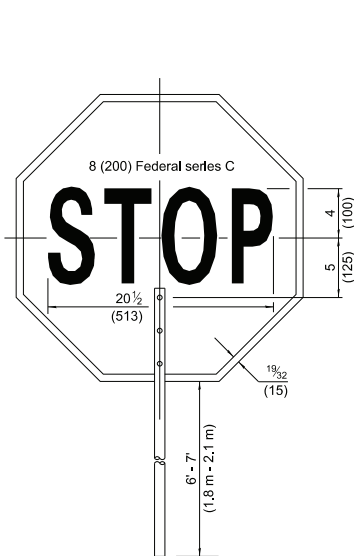

FRONT SIDE

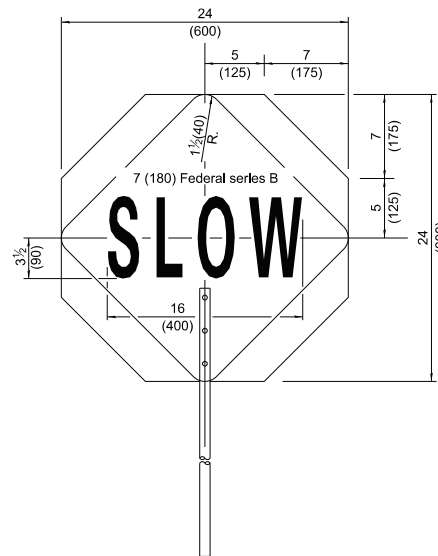

REVERSE SIDE

FLAGGER TRAFFIC CONTROL SIGN

ROAD CONSTRUCTION NEXT X MILES	END CONSTRUCTION
G20-1104(0)-6036	G20-1105(0)-6024

This signing is required for all projects 2 miles (3200 m) or more in length.

ROAD CONSTRUCTION NEXT X MILES sign shall be placed 500' (150 m) in advance of project limits.

END CONSTRUCTION sign shall be erected at the end of the job unless another job is within 2 miles (3200 m).

Dual sign displays shall be utilized on multi-lane highways.

WORK LIMIT SIGNING

WORK ZONE	W21-1115(0)-3618
SPEED LIMIT XX	R2-1-3648
PHOTO ENFORCED	R10-1108p-3618 ****
\$XXX FINE MINIMUM	R2-1106p-3618

Sign assembly as shown on Standards or as allowed by District Operations.

END WORK ZONE SPEED LIMIT	G20-1103-6036
---------------------------------	---------------

This sign shall be used when the above sign assembly is used.

**HIGHWAY CONSTRUCTION
SPEED ZONE SIGNS**

**** R10-1108p shall only be used along roadways under the jurisdiction of the State.

**TRAFFIC CONTROL
DEVICES**

(Sheet 2 of 3)

STANDARD 701901-09

Illinois Department of Transportation

APPROVED	January 1, 2024	ISSUED 1-1-2024
ENGINEER OF SAFETY PROGRAMS AND ENGINEERING	<i>[Signature]</i>	
APPROVED	January 1, 2024	
ENGINEER OF DESIGN AND ENVIRONMENT	<i>[Signature]</i>	

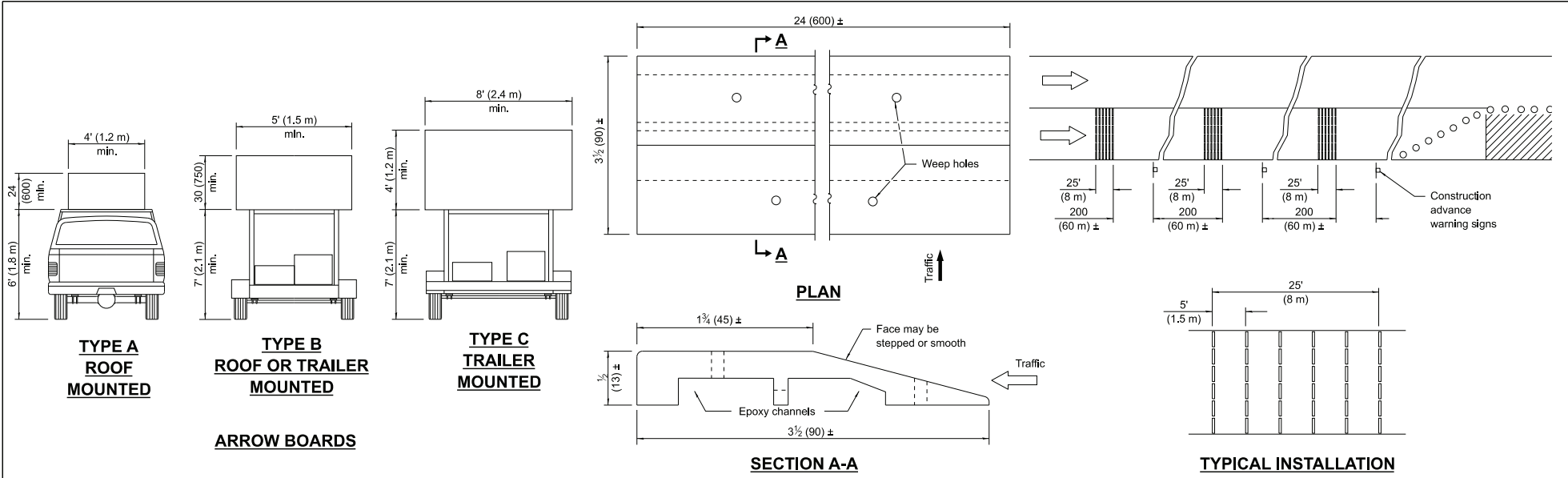

**TYPE A
ROOF
MOUNTED**

**TYPE B
ROOF OR TRAILER
MOUNTED**

**TYPE C
TRAILER
MOUNTED**

ARROW BOARDS

SECTION A-A

TYPICAL INSTALLATION

TEMPORARY RUMBLE STRIPS

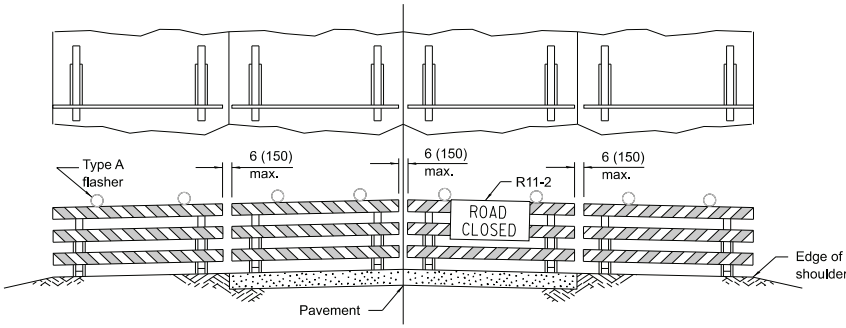

ROAD CLOSED TO ALL TRAFFIC
Reflectorized striping may be omitted on the back side of the barricades.

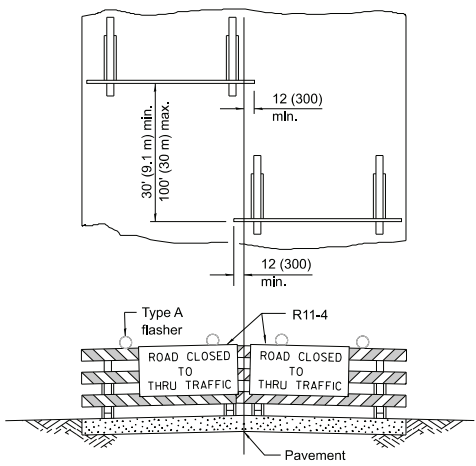

ROAD CLOSED TO THRU TRAFFIC
Reflectorized striping shall appear on both sides of the barricades.

**TYPICAL APPLICATIONS OF
TYPE III BARRICADES CLOSING A ROAD**

If a Type III barricade with an attached sign panel which meets NCHRP 350 or MASH is not available, the sign may be mounted on an NCHRP 350 or MASH temporary sign support directly in front of the barricade.

**TRAFFIC CONTROL
DEVICES**

(Sheet 3 of 3)

STANDARD 701901-09

Illinois Department of Transportation

APPROVED January 1, 2024

ENGINEER OF SAFETY PROGRAMS AND ENGINEERING

APPROVED January 1, 2024

ENGINEER OF DESIGN AND ENVIRONMENT

DESIGNED